

Kyogle Council

Road Reserve Management Plan



Table of Contents

1	PURPOSE	4
2	OBJECTIVES	4
2.1	Council controlled road reserves.....	4
3	SCOPE	4
4	DISCUSSION	4
5	USE OF FOOTPATH AND NATURE STRIP AREAS	5
5.1	Temporary Footpath Hoardings	5
5.2	Permanent Structures	5
5.3	Portable Advertising Structures.....	6
5.4	Street Vending.....	6
5.5	Footpath Restaurants.....	7
6	OTHER USES FOR PUBLIC ROAD RESERVES	8
6.1	Events Within The Road Reserve	8
6.2	Leasing Of Unused Road Reserves	8
6.3	Permanent Structures Within the Road Reserve	8
6.4	Closing of Roads	9
6.4.1	Temporary Road Closures.....	9
6.4.2	Permanent Road Closures.....	9
7	MAINTENANCE OF EXISTING STRUCTURES.....	9
8	MAINTENANCE OF ROADSIDE VEGETATION	10
8.1	Mowing of Roadside Areas	10
8.1.1	Mowing of Roadside Areas using Hand and Ride On Mowers.....	10
8.1.2	Mowing of Roadside Areas using Tractor Mounted Devices.....	10
8.2	Lopping and Removal of Trees	11
8.3	Roadside Grazing of Stock	11
9	ROADSIDE FENCING	11
9.1	Specifications	12
9.1.1	Main Roads (Summerland Way and Bruxner Highway)	12
9.1.2	All Rural Roads	12
9.1.3	Urban Streets.....	12
9.1.4	Electric Fencing	12
10	ERECTION OF PRIVATE STRUCTURES	12
10.1	Non-approved Structures	13
10.2	Application to erect private structure	13
10.3	Road Crossings	13
10.3.1	Road Crossing by Excavation.....	13
10.3.2	Road Crossing by Under-bore	14
11	EXTERNAL SERVICE PROVIDERS.....	14
11.1	Maintenance of existing infrastructure.....	14
11.2	Construction and Alteration of Infrastructure.....	14
12	WORKS UNDERTAKEN BY COUNCIL	14
13	REGISTRATION OF APPROVED CONTRACTORS.....	14
14	PRIVATELY CONDUCTED (EXTERNAL) WORKS.....	15
14.1	Plans of the Works	15
14.2	Approval to Conduct Works.....	15
14.3	Approval to Commence Works.....	16
14.4	Inspection of the Works	16
14.4.1	Assessment Inspection	16
14.4.2	Pre-start Inspection	16
14.4.3	During Construction Inspection.....	16
14.4.4	Works As Executed Inspection	16
14.4.5	Bond Release Inspection.....	16
14.5	Additional Inspections.....	17
15	CONDITONAL APPROVALS	17
15.1	Standard Conditions	17
16	UNDERTAKING OF WORKS	19
16.1	Work Methods	19
16.2	Work Standards and Specifications	19

16.3	Non-Complying Works.....	19
16.3.1	Non-Conformances.....	20
16.3.2	Stop Work Order.....	20
	APPENDIX A – EXTRACTS FROM RELATED LEGISLATION.....	22
	APPENDIX B – SECTION 138 AGREEMENT.....	33
	APPENDIX C – OHS&R MANAGEMENT PLAN GUIDELINES.....	42
	APPENDIX D – ENVIRONMENTAL MANAGEMENT PLAN GUIDELINES.....	47
	APPENDIX E – APPLICATION TO CONDUCT WORKS IN ROAD RESERVE.....	49
	APPENDIX F – NOT USED.....	53
	APPENDIX G – NOT USED.....	54
	APPENDIX H – STANDARD ROAD CROSSING.....	55
	APPENDIX I – NON-COMPLYING WORKS INSPECTION FORM.....	56
	APPENDIX J – STANDARD DRAWINGS FOR ROADSIDE FENCING.....	57

1 PURPOSE

Council's document titled **Road Reserve Management Plan** is intended to give guidance to Council staff, contractors and land owners in matters relating to performing works within the public road reserve, and the management of public road reserves under Council's control. This document outlines the application processes and requirements to be met prior to conducting works, and the procedures to be followed whilst undertaking works.

2 OBJECTIVES

2.1 Council controlled road reserves

Within the available resources of council's to:

- Provide safe roads for use by road users;
- Provide for appropriate management of road reserves

To assist in meeting the Strategic Governance targets outlined in Council's Management Plan;

- To identify and address the needs for the improvement of the Rural Local Road Network and to improve the level of service to the general public and residents of the Council area
- Promote the responsible management of the roadside environment
- Promote road safety
- To control private structures on roads and road openings and to ensure all works are carried out to adopted standards

3 SCOPE

This document applies to all activities conducted within any road reserve where Kyogle Council is the Road Authority. This includes all maintenance and construction of any temporary or permanent structures or infrastructure, and any events or proceedings within the road reserve. This document also covers works on any Council controlled infrastructure assets outside the road reserve and any works on infrastructure that is to be transferred to Council upon acceptance of works.

4 DISCUSSION

In addition to the works and services conducted by Council many other individuals and organisations may also conduct works and events within the road reserves or on assets under Council's control. In order to protect both Council and the general public Council needs to put in place systems and procedures to ensure that these works are being carried out by competent persons with appropriate insurance coverage.

In most cases these works will effect the flow of traffic and/or infrastructure owned by Council. Council needs to ensure that the safety of road users is maintained and that works do not result in a negative impact on Council's assets and the environment.

The scope of works conducted by individuals or organisations can vary greatly. Works can include the mowing of the nature strip in a village area, through to major road, telecommunications, electricity, water, sewerage and drainage construction works, and everything in between. Council has endeavoured to make its requirements suit the scope of the works being conducted. To this effect the

requirements for minor maintenance works are not as stringent as those for major construction works where project specific Quality, OH&S, and Environmental Management Plans may be required.

In most cases Council have provided an outline of the requirements to obtain approval for conducting works or events. In some cases this is not practical and individual assessment of proposals is the only equitable way to determine the requirements for specific projects.

In the case of Public Gates and Bypasses (Cattle Grids) and Property Accesses separate management plans have been prepared outlining the specific requirements in relation to the assessment and approval of these structures. In all cases the application to actually conduct the construction works must still be made in accordance with this document.

5 USE OF FOOTPATH AND NATURE STRIP AREAS

5.1 Temporary Footpath Hoardings

Temporary Footpath Hoardings are generally associated with works that would also require a Development Application. For applications to use footpath or nature strip areas as hoardings, or for unloading and loading of goods, a written proposal should be forwarded to Council detailing the proposed use, duration of use, and reason for requiring the use of the road reserve. Applications will be assessed on an individual basis at the discretion of the Director of Technical Services.

5.2 Permanent Structures

No permanent structures are to be placed on the footpath or nature strip areas without prior approval by Council. In areas subject to high pedestrian traffic and commercial activity, there should be no permanent structures erected within the first 2.5m from the building line to ensure that a clear passage is maintained along the shop fronts. The preferred area for placement of street furniture such as seats, signposts, bins, light poles etc is within the first 1.0m from the back of the kerb line.

The only permanent structures to be considered for placement within the 2.5m clear zone are public seating providing the following criteria are met;

- That the seat does not have any glass immediately behind or up to 500mm above the seat back to avoid damage to adjacent property
- That the adjacent business is not a licensed premises or food premises
- There must be a 2.4m clear footpath width left between the seat and any other permanent structure to allow for free movement of pedestrians
- That the operator of the adjacent business and owner of the property at the time of erection do not object to the placement of the structure. Objections from any subsequent owner or operator will not require removal of the structure once placed.
- That the seat is in front of the Chemist Shop located at 111 Summerland Way Kyogle.

The placement of any permanent structures within the remaining footpath and nature strip areas will be at the sole discretion of the Director Technical Services who will have regard to the following matters;

- The level of pedestrian and vehicular traffic in the area
- Any loss of sight distance or visibility between pedestrians and vehicular traffic

- Impacts on the visually impaired
- Accessibility issues associated with wheelchair access
- Access for street cleaning and garbage collection equipment
- Health impacts of the structure and associated uses
- Possible damage to adjacent areas
- Exposure of Council to civil liability claims

5.3 Portable Advertising Structures

All shopkeepers are permitted to display on the footpath a single A-frame style sign board per shop without any formal approval from Council. No fees or charges apply to the placement of A-frame style signs. Any such sign;

- must be placed within the shop frontage
- must encroach no further than 1.0m from the kerb line
- must be no bigger than 900mm wide,
- should be placed at the dividing line of the adjacent car parking bays wherever possible, to avoid interference with car doors and people entering and existing vehicles.

No other items including, but not limited to, signs, advertising material, amusement rides, storage, seats, tables are allowed on the footpath without formal approval from Council. Any permanent advertising structure will need to comply with the current planning instruments under the Environmental Planning and Assessment Act, and will likely require a separate Development Application.

5.4 Street Vending

Street vending or placement of goods for sale within the footpath areas will only be allowed;

- Where there is a Development consent in place for the activity such as Farmers Markets, or
- Where it is associated with a charity and has been previously authorised by Council, or
- In association with Kyogles “Red Hot Sale Day” or other such event previously endorsed by Council, or
- Where there is a formal Agreement in place between Council and the proprietor of the adjacent business

Council can consider an application from any business operating out of adjacent premises for a formal legally binding Agreement to permit street vending. The following requirements will apply in relation to the consideration and preparation of any such Agreement;

- No annual fees or application fees would be applied by Council
- Any goods or structures used in conjunction with the display or sale of goods shall not extend more than 700mm from the front of the shop alignment and shall not extend beyond the length of the shop frontage.
- The front entrance of the shop shall be kept unobstructed at all times.
- A clear distance of at least 2.0m in width is to be maintained between any goods displayed and any adjacent permanent structures at all times so as to not interfere with pedestrian circulation.
- The goods placed for sale must not be dangerous goods, liquid, food, or any other material that is of a perishable nature or that may lead to spills or leaks on the footpath area
- Goods must be easily visible and preferably make use of contrasting colours for the visually impaired

- All structures must be portable and removed from the footpath at the close of business
- The footpath must be kept in a clean and tidy state by the shop owner
- Shop owners must have public liability insurance for a minimum \$10,000,000 and must list Council as an interested party
- The shop owner shall indemnify Council against all claims of public liability

Any applications for a Street Vendors Agreement must be made in writing and include details of the goods proposed to be placed on the footpath for sale. The application will be assessed and determined by the Director Technical Services who can execute a formal Agreement where the above criteria can be met.

5.5 Footpath Restaurants

Footpath dining areas will only be allowed;

- Where there is a Development consent in place for the adjacent food premises or restaurant, and
- Where there is a formal Agreement in place between Council and the proprietor of the adjacent business

Council can consider an application from any food premises or restaurant operating out of adjacent premises for a formal legally binding Agreement to permit footpath dining. The following requirements will apply in relation to the consideration and preparation of any such Agreement;

- No annual fees or application fees would be applied by Council
- Dining areas must be appropriately delineated (by way of suitable barriers) with easily visible and contrasting colours for the visually impaired
- No smoking in footpath dining area
- No animals are permitted in, or adjacent to, footpath dining areas, excepting guide dogs used by the blind or visually impaired
- Any structures used in conjunction with the footpath dining area shall not extend more than 1.5m from the front of the shop alignment and shall not extend beyond the length of the shop frontage.
- The front entrance of the shop shall be kept unobstructed at all times.
- A clear distance of at least 1.2m in width is to be maintained between any goods displayed and any adjacent permanent structures at all times so as to not interfere with pedestrian circulation.
- All structures must be portable and removed from the footpath at the close of business
- The footpath must be kept in a clean and tidy state by the shop owner
- Shop owners must have public liability insurance for a minimum \$10,000,000 and must list Council as an interested party
- The shop owner shall indemnify Council against all claims of public liability

Any applications for a Footpath Dining Agreement must be made in writing and include details of the proposed layout of the dining area, and the materials to be used for barriers and furniture. The application will be assessed and determined by the Director Technical Services who can execute a formal Agreement where the above criteria can be met.

6 OTHER USES FOR PUBLIC ROAD RESERVES

6.1 Events Within The Road Reserve

Any events proposed within the road reserve will require Council approval. This includes, but is not limited to, roadside stalls, road closures for parades or protest rallies, and sporting events such as fun runs and endurance horse riding events. In some cases Council may not impose any fees and charges, but may still require appropriate signage or notification of the proposed events.

Other events that may not actually be conducted within the road reserve may still require notification to Council. These would include events that were expected to attract a significant number of people and/or generate significant pedestrian or vehicle traffic or potential parking problems. Again Council may not impose any fees or charges in relation to the event, but will provide guidance in relation to the management of the impacts on the road users.

Groups or organisations wishing to conduct events within the road reserve or other significant events are encouraged to consult with Council to ensure all parties involved are aware of any requirements relating to the proposed event. If the applicant wishes Council to provide assistance with traffic management during the course of an event, this should also be requested in writing.

All applications will be assessed and determined at the discretion of the Director of Technical Services.

6.2 Leasing Of Unused Road Reserves

Council will consider an application to lease a road reserve for any purpose allowed under the Roads Act 1993. Leases cannot be granted for any period longer than five years. All applications should be made in writing detailing the proposed use. Fees and charges apply to the application process and the lease, if granted. These fees and charges are set down by Council in their Management Plan.

Applications will be assessed and approved at the discretion of the Director Technical Services.

6.3 Permanent Structures Within the Road Reserve

No permanent structures can be erected on a road reserve even where the road reserve is under a lease agreement. If any existing permanent structures are encroaching onto a road reserve an application to lease the road reserve does not resolve the encroachment. Any permanent structure or part of a permanent structure encroaching onto a road reserve under Council's control is the property of Council. If the adjoining land owner wishes to resolve the encroachment they must make application to close the road reserve, or part of the road reserve effected by the encroachment.

Applications will be assessed in accordance with section 6.4.2 of this document.

6.4 Closing of Roads

This includes both the temporary closure of roads to conduct works and/or events, and the permanent closure of roads to create freehold land.

6.4.1 Temporary Road Closures

Temporary road closures will require an application to Council to conduct the works or events associated with the need to close the road. In addition to the standard notification period required for the proposed works or event a further 30 days notice is required where the proposal requires the closure of a road for any time greater than ten (10) minutes.

Council is required to advertise the intention to close the road for a period of 28 days prior to the proposed closure. An additional fee will apply to cover the cost of this advertisement.

In the case of an emergency situation this fee and notification period do not apply, but notification to Council's office or after hours emergency contact number will still be required.

6.4.2 Permanent Road Closures

Applications to permanently close a Council controlled public road reserve must be made in writing. All applications will be assessed on an individual case by case basis.

In general the applicant will be required to cover all costs associated with the road closure process. If the applicant wishes to subsequently purchase the land created by the road closure they will be liable for the purchase costs determined under the Land Acquisition (Just Terms Compensation) Act 1991, in addition to the costs of the roads closure process.

Council staff will assess the proposed road closure and make a recommendation to Council. Following a resolution by Council the applicant will be advised in writing of Council's decision on the matter. The closure of the road reserve may not be possible if it "land locks" a parcel of land, or if Council wishes to retain the road reserve for any purpose such as future expansion of the road network.

7 MAINTENANCE OF EXISTING STRUCTURES

Minor and miscellaneous maintenance of existing structures such as Property Accesses and Public Gates and Bypasses (Cattle Grids) is permitted provided the following conditions are met;

1. Works do not involve a Temporary Road Closure (refer Section 6.3.1)
2. Council are to be notified at least 14 days prior to works. A standard application form and checklist is shown in APPENDIX E.
3. The person conducting the works has appropriate public liability insurance in place, and Council have been provided with evidence of this meeting the following requirements;
 - a. Minimum coverage of \$10,000,000, and
 - b. Kyogle Council are listed as an interested party, and
 - c. Coverage includes conducting the specific works identified
4. Appropriate Safe Work Method Statements are provided and followed.
5. Council's is advised of how traffic will be managed during the course of works. Any Traffic Control Plan to be used must be submitted to Council and signage must be in place during the course of works.

Council will assess the information provided and if the proposal is approved the applicant will be advised in writing. If the information required above is not provided Council will advise the applicant of the outstanding requirements.

8 MAINTENANCE OF ROADSIDE VEGETATION

Council will maintain the roadside vegetation within the resources allocated and in accordance with the Kyogle Council Road Network Management Plan. The works undertaken by Council do not always provide for the level of service some land owners may desire. In addition to the works undertaken by Council, Council recognises that some individuals wish to undertake maintenance of roadside vegetation at their own expense. Council understands the importance of allowing land owners to maintain the roadside vegetation fronting their land and will allow this to be done in accordance with the processes outlined in this document.

8.1 Mowing of Roadside Areas

8.1.1 Mowing of Roadside Areas using Hand and Ride On Mowers

Prior approval from Council is not required for mowing of roadside areas where;

1. A hand mower with catcher or guards is used, or
2. A ride-on mower with guards is used, and
3. The works do not encroach onto the trafficable surface of the road

Individuals to conduct these works are responsible for ensuring no debris enters the trafficable surface of the road.

8.1.2 Mowing of Roadside Areas using Tractor Mounted Devices

Council may grant approval for mowing of roadside areas using tractor mounted devices provided the following conditions are met;

1. Application is to be made to Council at least 14 days prior to proposed date of commencing works. A standard notification form and checklist is shown in APPENDIX E. The period of the approval can be extended to the end of each financial year and renewed annually.
2. Works do not involve a Temporary Road Closure (refer Section 6.3.1)
3. The person conducting the works has appropriate public liability insurance in place, and Council have been provided with evidence of this meeting the following requirements;
 - a. Minimum coverage of \$10,000,000, and
 - b. Kyogle Council are listed as an interested party, and
 - c. Coverage includes conducting the specific works identified
4. Appropriate Safe Work Method Statements are followed. To this end Council have available Safe Work Method Statements for the use of Tractor Mounted Slashers and Ride on Mowers. Copies are available upon request.
5. Appropriate Traffic Control Measures are in place. To this end Council can supply copies of standard Traffic Control Plans and signage is available for hire from Council's depots.
6. Council is notified at least 1 hour prior to the commencement of works, including erection of signs.

Once approval is granted Council can provide a package to each successful applicant which includes;

1. Standard Traffic Control Plans Applicable to roadside slashing
2. Signage in accordance with the standard TCP for daylight use only

3. Safe Work Method Statements for Use of Tractor Mower Operation and Traffic Control Sign Erection and Removal
4. Standard Risk Assessment form
5. List of Council contacts for notification prior to commencing works

8.2 Lopping and Removal of Trees

If a Customer Action Request is made requesting the lopping or removal of a tree or trees within the road reserve, Council will conduct an inspection and assess the risk associates with the tree/s in question. If Council deems that the tree/s require removal or lopping then they will be allocated a priority and dealt with as resources allow.

Where an individual or an organisation wishes a tree or trees to be removed from within the road reserve and Council does not deem the tree/s to be a risk to road users or property, and application can be made to Council in writing for removal of the tree/s at the expense of the applicant. Council will assess the proposal and notify the applicant if the proposal is approved or not.

If approved, the applicant will be notified of the conditions relating to the removal or lopping process. This notification does not represent approval to conduct the physical works. The actual contractor must make application to Council to conduct the works in accordance with the written approval.

8.3 Roadside Grazing of Stock

Council will permit roadside grazing of stock where a Roadside Grazing Stock Permit has been issued. Roadside Grazing Stock Permits are granted by the Rural Lands Protection Board under the provisions of the Rural Lands Protection Act 1998, Part 8, Division 5, Section 102.

The applicant should obtain an Application for Roadside Grazing Stock Permit form from the Rural Lands Protection Board. The form is to be completed and submitted to Council prior to the Rural Lands Protection Board. Council will require evidence the applicant has appropriate public liability insurance in place meeting the following requirements;

- a. Minimum coverage of \$10,000,000, and
- b. Australia Wide Coverage

Authorisation of the application will be at the discretion of the Director Technical Services who will take into account all matters including, but not limited to;

- The classification of the road/s
- Any planned or current works in the area
- The size, number and nature of the stock
- Local use of the road including bus routes

In general a fee will be charged by Council in accordance with Council's Management Plan, but in the case of areas which are drought declared at time of application this fee will be waived.

9 ROADSIDE FENCING

Roadside fencing refers to the fencing along the road reserve boundary, usually parallel to the constructed roadway. Roadside fencing is the responsibility of the owner of the property adjoining the public road. It is also the property owners responsibility to verify property and road reserve boundaries prior to fencing. Council

may require the boundary between private property and the public road reserve to be fenced, but will not generally do so unless there are issues with containment of stock.

The specifications provided below identify a minimum acceptable standard. All fencing is to be kept and maintained to ensure containment of stock.

9.1 Specifications

Council has specified minimum standards for roadside fencing based on the type of road and its location. These standards are provided as a minimum standard, if an alternate fencing system can be demonstrated to be as effective or more effective than that specified above, then this alternative can be considered for approval at the discretion of the Director Technical Services. Applications should be made in writing prior to commencing construction.

APPENDIX J contains some standard drawings for fencing from various sources. None of these is specified as Council's standard they are provided for reference on construction methods and material types. If the standard drawing and the specifications listed below do not agree, the specifications below will prevail.

9.1.1 Main Roads (Summerland Way and Bruxner Highway)

- Five (5) strand wire fencing
- Posts at three (3) meter spacings
- Wires at 225mm spacings

9.1.2 All Rural Roads

- Four (4) strand barbed wire fencing
- Posts at four (4) meter spacings
- Wires at 225mm spacings

9.1.3 Urban Streets

- Four (4) strand wire fencing
- Posts at three (4) meter spacings
- Wires at 225mm spacings

9.1.4 Electric Fencing

- Electric fencing must not be erected on the road reserve boundary
- Any electric fencing must be erected a minimum of 300mm inside the road reserve fencing
- Electric fencing must not be used where there is not roadside fencing in accordance with the specifications shown above

Note: The above provisions do not apply in emergency situations where the electric fence is used as a temporary barrier to contain stock where the existing fence has been damaged by causes out of the control of the adjoining land owner such as landslip, flood or fire.

10 ERECTION OF PRIVATE STRUCTURES

Erection of any private structure within the road reserve must be approved by Council. This includes all non-permanent structures that are not covered by other sections of this document or separate documents such as in the case of Property Accesses and Public Gates and Bypasses (Cattle Grids) . This includes, but is not limited to, roadside mailboxes, gardens, signage, pipes and conduits.

10.1 Non-approved Structures

Any structure erected within the road reserve that has not been approved by Council may be removed by Council at Council's discretion. This will apply retrospectively in the case of all structures erected without written approval of Council.

10.2 Application to erect private structure

Any person wishing to erect a non-permanent private structure within the road reserve or to obtain approval for an existing non-permanent private structure must make written application to Council and include details of the location and nature of the proposed structure and its intended use. This should also include justification for the structure needing to be located within the public road reserve.

If approved the applicant will be notified of the conditions relating to the erection of the structure. This notification does not represent approval to conduct the physical works. The actual contractor must make application to Council to conduct the works in accordance with the written approval. In the case of minor non-permanent structures the application form shown in APPENDIX E can be used.

10.3 Road Crossings

All road crossings will require the submission of an application in writing for a Road Opening Permit. This application process will incur the appropriate fee in accordance with Council's Management Plan. Whilst other service providers such as Country Energy and Telstra are exempt from this application fee, they must still make a formal application for the proposed works.

The crossing of sealed roads is not generally accepted by way of open trenching excavation. Under-boring methods should be used to lay services across road. Only in exceptional circumstances will open trenching of sealed roads be considered and must be approved by the Director Technical Services.

10.3.1 Road Crossing by Excavation

Where a Road Opening Permit has been issued and the road crossing is to be made by excavation the contractor wishing to conduct the excavation will be required to make application and will be required to complete a **Section 138 Agreement**. In these cases a construction bond will be required to be paid prior to the start of works. The amount of the bond will be determined by the Director Technical Services taking into account the standard and condition of the road pavement in the area of excavation. This bond amount shall be no less than \$300. Other Service Providers such as Country Energy and Telstra are required to pay this bond amount.

The proposed excavation must be conducted in one of the following three ways;

1. At all times while the work is in progress half of the road width is to be kept open to traffic. Work on one side is to be completed, compacted and shaped to finished level prior to excavation being carried out on the other side of the road, or
2. If this is not practical or possible then the applicant is to construct a traffic bypass to a standard as approved by the Director Technical Services to enable the level of service of the road to be maintained, or
3. The applicant must make application for a Temporary Road Closure in accordance with section 6.4.1 of this document. Additional notification period and fees will apply.

All cables and pipes crossing Council's roads are to be encased in an appropriate conduit. In the case of private road crossings this conduit must extend to within the private property on both sides of the road. Refer to APPENDIX H.

10.3.2 Road Crossing by Under-bore

Where a Road Opening Permit has been issued and a road crossing is to be made by Under-bore or other trenchless technology where the road pavement is not disturbed, Council will not require a **Section 138 Agreement** providing the equipment used will not encroach on the area above the surface of the road reserve during the course of the works. In these cases the application shown in APPENDIX E can be used.

11 EXTERNAL SERVICE PROVIDERS

Many external service providers own and maintain infrastructure within the road reserve. Some of these organisations are exempt from the payment of fees in relation to seeking approval to conduct works within the road reserve, but in all cases the approval of Council must be obtained prior to commencing works. The only exception to this rule is in the event of emergencies.

11.1 Maintenance of existing infrastructure

In the case of minor maintenance works on existing infrastructure Council does not require the service provider to make application to Council to conduct maintenance works where;

- pedestrian and road traffic are not affected, and
- environmental impacts are negligible, and
- no new infrastructure is to be installed, and
- the service provider has appropriate Safe Work Procedures in place

11.2 Construction and Alteration of Infrastructure

In the case where new infrastructure is proposed or alterations to existing infrastructure are proposed Council will require written notification to be received a minimum of 14 days prior to the proposed commencement date. This notification should include details of the proposed works and details of the environmental considerations addressed during the service providers planning stages. Where the proposal will impact on pedestrian or road traffic details of the proposed traffic management will also be required.

If Council objects to the proposal or has any additional requirements the relevant agency will be provided with details of these in writing prior to the proposed commencement date. Where required Council or the service provider may request a site inspection to verify the requirements of either party. No fees or charges will apply to this process.

12 WORKS UNDERTAKEN BY COUNCIL

Any works undertaken by Kyogle Council are exempt from the requirements of this Management Plan. This includes sub-contractors working on Council behalf.

13 REGISTRATION OF APPROVED CONTRACTORS

Council will provide a system for contractors to register for pre-approval to conduct works within the road reserve and on Council owned assets. A list of all contractors that obtain this pre-approval will be made available individuals or organisations who require works to be conducted.

This pre-approval process is not mandatory, nor does it exclude contractors from making application to conduct specific works. This pre-approval process allows contractors to provide Council with the appropriate information as listed in this document so that Council can advise people of the contractors suitability to conduct works.

A Register of Approved Contractors will be maintained and provided to individuals and organisations upon request. This register shall list the following information;

- Name of Contractor
- Postal Address of Contractor
- Name and phone number of contact
- List of all activities the Contractor has been pre-approved to conduct

14 PRIVATELY CONDUCTED (EXTERNAL) WORKS

This refers to works which are required through development conditions, privately maintained structures such as Public Gates and Bypasses Cattle Grids) and Property Accesses, or where an individual or organisation wishes to conduct works where the work relates to an asset that is owned by Council or is to be transferred to Council upon acceptance of works.

In the case of developer works this will require approval of design plans prior to applying to conduct works. Approval of Property Accesses, issuing of Public Gate Permits, notices of repairs required to existing structures, and approval of design plans do not constitute an approval to conduct works. A separate application must be made prior to commencing works in accordance with this document.

14.1 Plans of the Works

In all cases where standard drawings are not supplied or approved for use Council will require the submission of detailed design plans for approval prior to any approval for works being granted. Once approved these plans will be stamped and copies returned to the applicant. The fees and Charges listed in Council's Management Plan will be applied during this process. At the completion of the works Council will require the submission of a Works As Executed plan completed by a registered surveyor or qualified engineer.

14.2 Approval to Conduct Works

Once the design plans for the proposed works have been approved Council will notify the applicant of any additional conditions relating to the proposed works. A list of some typical conditions are shown under section 14.1 of this document.

An approval to conduct works is issued in writing by Council detailing the conditions of the approval. This approval only remains current for the time period specified on the approval. During the course of conducting works the contractor is to ensure a copy of the approval is kept on site at all times and must produce this approval at the request of Council staff.

14.3 Approval to Commence Works

Once conditional approval has been obtained for the proposed works the contractor wishing to conduct the works must make application to Council. Typically the contractor will be required to supply details of their organisation and any relevant safety, quality, and environmental management plans they have in place. In addition to these proof must be provided of insurance coverage and any other site specific requirements.

The contractor will be required to complete the attached **Section 138 Agreement** in relation to each specific works proposal. A copy of the **Section 138 Agreement** must also be kept on site at all times.

14.4 Inspection of the Works

In general the Engineer: Asset Services and the Design Engineer are responsible for the verification of External Works. Generally the Design Engineer will inspect and verify works on Vehicular Accesses, Public Gates and Grids, and road excavations. Any developer works and other External Works are generally inspected and verified by the Engineer Asset Services.

Council's standard fees and charges for assessing and approving design plans, Public Gate Permits, and Property Access permits, include the provision of the required inspections. These are;

14.4.1 Assessment Inspection

Generally conducted by a Council officer only. This inspection allows for the assessment of the proposed works and allows any site specific issues to be identified and addressed.

14.4.2 Pre-start Inspection

This inspection is to be conducted prior to commencing works when traffic control and erosion sedimentation control devices have been established. Any issues relating to the design plans or standard drawings should be resolved at this point and notification of any variations to the proposed works will be documented.

14.4.3 During Construction Inspection

This inspection is to be conducted as works near their completion so that any outstanding matters can be identified prior to the contractor leaving the site.

14.4.4 Works As Executed Inspection

This inspection will be conducted upon submission of Works As Executed plans or notification of the completion of works. If a representative from the contractor and/or the developer wishes to be present Council are to be notified upon submission of the Works As Executed plans or notice of completion of works. Any inconsistencies or errors or omissions will result in the works not being accepted by Council. Any bond period will commence from the date of the approval of the Works As Executed Plans by Council. In the case of Public Gates and Bypasses (Cattle Grids) and Property Accesses the bond monies will be refunded upon acceptance of works.

14.4.5 Bond Release Inspection

This inspection will be conducted once any maintenance bond period has expired. If a representative from the contractor and/or the developer wishes to be present Council are to be notified at least 14 days prior to the expiration of the bond period to arrange for inspection time and date. Any outstanding works will be advised to the contractor in writing and will need to be addressed prior to release of any bonded

monies. If works are not completed within 14 days Council will conduct the works and retain the bonded monies.

14.5 Additional Inspections

Any additional inspections requested by the contractor or developer are subject to the fees and charges as listed in Council's Management Plan. Payment of the appropriate fees and charges and notification of at least 24 hours are required prior to conducting additional inspections.

15 CONDITONAL APPROVALS

When notifying an applicant that an application to conduct works has been approved Council will advise if this approval is subject to any conditions. If any conditions are applicable to the approval the applicant will be notified in writing with each condition detailed. Below is a list of some typical conditions that Council may impose as it sees fit. This is in no way an exhaustive list and other conditions may be imposed as appropriate to the individual proposal.

15.1 Standard Conditions

The following conditions are typical standard conditions that may be applied as deemed appropriate. Any other conditions not listed below specific to the proposed works may be determined by the Director Technical Services as required.

15.1.1

Full engineering design plans for the proposed works are to be submitted for approval prior to the commencement of work. Design is to be in accordance with Council's specifications. A plan checking and inspection fee is to be paid in accordance with the Fees and Charges listed in Council's Management Plan.

15.1.2

A maintenance period shall apply to all construction carried out on assets where ownership lies with, or is to pass to, Council. The maintenance period shall extend from the completion of works and subsequent approval by Council, for six months. Within that time the applicant is responsible for any omissions or defects arising. At the end of the maintenance period Council will inspect the works and any work not found to be conforming shall be the responsibility of the applicant to rectify.

15.1.3

A maintenance bond is to be paid to Council prior to the commencement of works. The amount of this bond is to be calculated on the estimate of cost of the works as follows;

Estimate of costs of works	Maintenance bond amount
Less than \$2,000	Nil
\$2,000 to \$20,000	5% of estimate
\$20,001 to \$100,000	\$1,000 plus 2.5% of estimate over \$20,000
Over \$100,000	\$3,000 plus 1% of balance over

	\$100,000
--	-----------

The maintenance bond shall be returned at the completion of the maintenance period and subsequent approval by Council.

15.1.4

A certified "Works As Executed" plan from a qualified Engineer or Registered Surveyor is to be submitted before the final inspection certifying that the works have been constructed in accordance with the drawings and to the levels specified.

15.1.5

Prior to commencing the work the contractor must show evidence of holding current Public Liability Insurance of not less than \$10 million, listing Kyogle Council as an interested party.

15.1.6

Prior to commencement of work the contractor must submit a Traffic Control Plan showing how traffic will be managed while work is being carried out within the Road reserve. (Standard TCPs are available from Council's Technical Services Department.)

15.1.7

Prior to commencing work the location of all services (eg Telstra cables, water services etc) in the vicinity is to be determined and measures taken to prevent damage to those services. Any cost of repair because of damage to these services will be the applicants responsibility.

15.1.8

All work areas and excavations within the Road Reserve are to be fully restored to their original condition and to the satisfaction of the Director Technical Services on completion.

15.1.9

During the course of works, and for a period following the completion of the works Council requires that sedimentation/erosion controls are put in place to avoid pollution or adverse effects on the surrounding environment.

15.1.10

Council is to be notified upon completion of the works at which time an inspection will be undertaken.

15.1.11

Council reserves the right to conduct works to restore damage to its infrastructure or remove obstructions from the road reserve with all costs to be recovered from the applicant.

15.1.12

No loose material or soils to be left at any time on the existing road or footway areas. Excess material is to be removed from the road reserve and the site left in a clean and tidy condition.

15.1.13

It is not permitted to dump excess material on any road reserve within the Kyogle Local Government Area under the control of Council. Disposal at suitable sites of excess material can be advised by the Manager Engineering Works.

15.1.14

All plant used in the carrying out of works shall be registered for road use and shall be safe and serviceable in accordance with Workcover requirements. All operators involved in the use of plant shall hold the appropriate certification to operate the plant.

15.1.15

All works shall be carried out in accordance with Workcover requirements and the Occupational Health and Safety regulations.

16 UNDERTAKING OF WORKS

16.1 Work Methods

In all cases where works are within the road reserve under traffic the activity is considered high risk and a Safe Work Method Statement must be prepared and followed in accordance with the Occupational Health Safety and Rehabilitation Regulation 2000.

Safe Work Method Statements prepared and approved by Council for a particular work activity will be made available to individuals and contractors upon request. If a Safe Work Statement has not been prepared and approved by Council it is the responsibility of the applicant to provide one.

Where a Safe Work Method Statement is prepared and approved it must be followed. In all other cases works are to be conducted in a safe manner in accordance with standards and best practice at the time.

16.2 Work Standards and Specifications

Council will review and publish appropriate standards from time to time. At time of publication the Northern Rivers Construction Manual, and the Northern Rivers Development and Design Manuals show the standards to be adhered to.

In all cases where a site specific design plan has been submitted and approved, works are to be conducted to the standard/s shown or referenced on the approved plans. Where any standard drawings have been supplied by Council or have been approved by Council works are to be conducted in accordance with these standard drawings.

16.3 Non-Complying Works

Non-complying works are when there exists a deficiency in the work which makes the product unacceptable in terms of the specified requirements. In general evaluating non-complying works and deciding how to rectify them will be the responsibility of the Engineer Asset Services. In the absence of the Engineer Asset Services the Works Engineer will perform this task subject to review by the Director Technical Services. The officer identifying the non-complying works will be responsible for restricting further processing of non-complying works until a rectification method has been finalised.

The inspecting officer will be responsible for completing a Non-Complying Works Inspection Form as shown in APPENDIX I for any identified non-conforming works where the situation cannot be immediately resolved on site.

16.3.1 Non-Conformances

Where a contractor is working under its own quality system, Non-Conformances may be recorded on the subcontractor's Non-Conformance Report forms. The contractor shall notify the Engineer Asset Services if the Non-Conformance rectification involves a change from the applicable specifications or if there is a possibility that other project work could be affected. The Engineer Asset Services approval must be obtained in such instances. File a copy of the subcontractor's Non-Conformance Report and fill out a Non-Complying Works Inspection Form shown in APPENDIX I where Council has been involved in resolving the Non-Conformance, but do not fill out an internal Non-Conformance Report.

16.3.2 Stop Work Order

Council reserves the right to issue a Stop Work Order to any party undertaking works within the road reserve. Council may issue a Stop Work Order in the following circumstances;

- In any case where Council deems that works are not being undertaken safely or in accordance with an approved Safe Work Method Statement, or
- Where road users or pedestrians are deemed to be at risk due to the works, or
- Where the works are having an adverse impact on the surrounding environment, or
- Copies of documents required to be kept on site by this document or the written approval cannot be produced, or
- Works are being conducted other than in accordance with conditions of approval, or
- Works are being conducted other than in accordance with Council's standards and specifications, or
- The scope of works exceeds that which was originally applied for and approved by Council, or
- The works have not been approved by Council, or
- Works are being undertaken by any party other than those identified in the original application and approval

A Stop Work Order can be issued verbally by any officer of Council with the approval of the Director Technical Services. In the event of a Stop Work Order being given the officer giving the order will advise the contractor of the requirements of the order such as;

- Removal of all equipment from the road reserve or trafficable area
- Reinstatement of road surfaces
- Removal of individuals from the site
- Restoration works to be undertaken immediately
- Works required to be conducted by Council

Any costs associated with works required by Council will be recoverable from the contractor or individual the order is given to.

Within 48 hours the contractor or individual will be issued with written confirmation of the Stop Work Order, stating the reason for the order being issued, any conditions applying to the order, and any conditions that must be complied with prior to

recommencing works. Any costs incurred by the contractor or any other individual due to the issue of a Stop Work Order may not be claimed from Council.

APPENDIX A – EXTRACTS FROM RELATED LEGISLATION

Roads Act 1993

.....

97 Utility services to be located in conduits

(1) The roads authority for a public road in which there are conduits for the carriage of

utility services across the road may direct any person who is entitled to place utility services in, on or over the road:

- (a) to locate any new or replacement services in any such conduit, and
- (b) to pay to the roads authority such proportion as may be prescribed by the regulations of the costs incurred by the roads authority in connection with the construction of the conduit.

(2) The direction may specify the manner in which or the standard to which the direction must be complied with.

(3) A provision of an Act that authorises the provision of services in, on or over a public road does not authorise the provision of the services in contravention of this section.

98 Roads authority may require alteration of work located in, on or over public roads

(1) A roads authority may direct the person having control of any work or structure that is situated in, on or over a public road to alter the work or structure or the location of the work or structure.

(2) The direction may specify:

- (a) the manner in which or the standard to which, and
- (b) the period (being at least 28 days) within which, the direction must be complied with.

(3) If a person fails to comply with a direction under this section, the appropriate roads authority:

- (a) may make the alteration directed, and
- (b) must, if it makes the alteration, make any necessary consequential alteration to any connecting branch work.

(4) In making any such alteration, the roads authority must ensure that it does not do anything that might cause permanent damage to the work or structure concerned or that might prejudicially affect its use.

(5) The cost of an alteration made by, or at the direction of, the appropriate roads authority must be borne by that authority.

(6) Subsection (5) is subject to the provisions of:

- (a) any agreement between the roads authority and the person having control of the work or structure, and
- (b) any Act or law.

99 Private bodies to maintain or repair certain water supply and drainage works

(1) A roads authority may direct an irrigation corporation, a private irrigation board, a private drainage board or a private water trust (within the meaning of the *Water*

Management Act 2000) to repair or maintain any water supply work or drainage work:

(a) that is situated in, on or over a public road, and

(b) that is controlled by that body.

(2) The direction may specify:

(a) the manner in which or the standard to which, and

(b) the period (being at least 28 days) within which, the direction must be complied with.

(3) The private body concerned may appeal to the Minister against the direction.

(4) The decision of the Minister on an appeal is final.

100 Owner of private railway to maintain bridges and level crossings and roads under railway bridges

(1) If a public road passes over, under or across a private railway by means of a bridge or level crossing, the owner of the railway:

(a) must maintain the bridge or level crossing (and, in the case of an overbridge, the road under the bridge) in a satisfactory state of repair, and

(b) must, if the appropriate roads authority so directs, repair or replace the bridge or level crossing (or, in the case of an overbridge, the road under the bridge) in accordance with the direction.

(2) A direction referred to in subsection (1) (b) may specify:

(a) the manner in which or the standard to which, and

(b) the period (being at least 28 days) within which, the direction must be complied with.

(3) The owner of the private railway may appeal to the Minister against the direction.

(4) The decision of the Minister on an appeal is final.

101 Restoration of public road following excavation etc

(1) A roads authority may direct any person by whom a public road is dug up to restore the road to its previous condition.

(2) If a public road is damaged as a result of a leakage from, or breaking or bursting of, any object or work placed in, on or over the road, the appropriate roads authority may direct the person:

(a) who was responsible for placing the object or work in, on or over the road, or

(b) who has the care or control of the object or work, or

(c) whose act or omission caused the leakage, breaking or bursting, to restore the road to its previous condition.

(3) A direction under this section may specify:

(a) the manner in which or the standard to which, and

(b) the period (being at least 14 days) within which, the direction must be complied with.

(4) Instead of giving a direction under this section, a roads authority may take such action as is necessary to restore the road to its previous condition.

(5) The costs incurred by a roads authority in taking action under this section are recoverable from the person referred to in subsection (1) or (2), as a debt, in a court of competent jurisdiction.

(6) Nothing in this section authorises a roads authority to recover an amount greater than that necessary to restore the road to its previous condition.

102 Liability for damage to public road

- (1) A person who causes damage to a public road, or to any road work on a public road or any traffic control facility on a road or road related area within the meaning of the *Road Transport (General) Act 1999* (other than a road or road related area that is the subject of a declaration made under section 9 (1) (b) of that Act relating to all of the provisions of that Act), is liable to pay to the appropriate roads authority the cost incurred by that authority in making good the damage.
- (2) If damage referred to in this section is caused by a motor vehicle or vessel, the owner and the driver of the motor vehicle or, as the case may be, the owner and the master of the vessel are jointly and severally liable for the damage.
- (3) This section does not apply to ordinary wear and tear caused by reasonable use of a public road.
- (4) This section applies to tollways and to private roads that are classified roads in the same way as it applies to public roads.

.....

Division 3 Obstructions and encroachments

107 Obstructions and encroachments

- (1) A roads authority may direct:
 - (a) any person who causes an obstruction or encroachment on a public road, or
 - (b) the owner of any land that is used, or is able to be used, in connection with an obstruction or encroachment on a public road,
 to remove the obstruction or encroachment.
- (2) A direction under this section may specify the period within which the direction must be complied with.
- (3) In the case of an obstruction or encroachment that was created before the alignment of the road, or that is situated on a road that has not been aligned, the period specified in the direction must be at least 60 days.
- (4) This section does not apply to an obstruction or encroachment on a public road if its presence on the road is authorised by or under this or any other Act.
- (5) However, this section does apply to an obstruction or encroachment on a public road if its presence ceases to be authorised by or under this or any other Act

.....

Part 9 Regulation of works, structures and activities

Division 1 Footway restaurants

125 Approval to use footway for restaurant purposes

- (1) A council may grant an approval that allows a person who conducts a restaurant adjacent to a footway of a public road (being a public road that is vested in fee simple in the council) to use part of the footway for the purposes of the restaurant.
- (2) An approval may be granted on such conditions (including conditions as to payments in the nature of rent) as the council determines.
- (3) An approval may not be granted in respect of a footway of a classified road except with the concurrence of the RTA.
- (4) The term of an approval is to be such period (not exceeding 7 years) as is specified in the approval.
- (5) An approval lapses at the end of its term or, if the part of the footway the subject

of the approval ceases to be used for the purposes of a restaurant, when that use ceases.

126 Authority to erect structures

(1) A council:

(a) may authorise the holder of an approval to erect and maintain structures in, on or over any part of the footway the subject of the approval, or

(b) may, at the request and cost of the holder of the approval, erect and maintain any such structure.

(2) The council may erect and maintain structures in, on or over any part of the footway the subject of an approval for the protection of public health and safety.

127 Effect of approval

While an approval is in force:

(a) the use of the footway for the purposes of a restaurant, and

(b) the erection and maintenance of structures on the footway in accordance with an authorisation given in respect of the approval, are taken not to constitute a public nuisance and do not give rise to an offence against this or any other Act.

Division 2 Public gates

128 Roads authority may grant permit

(1) A roads authority may permit the occupier of any land through which an unfenced public road passes to erect a gate across the road at any place at which the road intersects a boundary fence.

(2) A permit may not be granted with respect to a classified road except with the concurrence of the RTA.

(3) A roads authority must cause notice of the granting of the permit to be published in a local newspaper.

(4) The occupier for the time being of the land to which a permit relates is taken to be the holder of the permit.

129 Erection and maintenance of public gates

(1) The holder of a public gate permit may, at any time after one month from the publication of the notice of the granting of the permit, erect a gate in accordance with the permit.

(2) The holder of a public gate permit must ensure that:

(a) a notice is attached to both sides of the gate bearing the words "PUBLIC GATE" in letters at least 75 millimetres high, and

(b) both the gate and the notice are maintained in good condition.

Maximum penalty: 10 penalty units.

130 Revocation of permit

(1) The roads authority may at any time revoke a public gate permit.

(2) The occupier of the land the subject of a public gate permit that has been revoked must remove the gate within one month after notice of the revocation is served.

Maximum penalty: 10 penalty units.

131 Effect of permit

While a public gate permit is in force, the public gate to which it relates is taken not to constitute a public nuisance and does not give rise to an offence against this or any other Act.

132 Offences with respect to public gates

(1) A person must not cause any damage to a public gate or to any notice attached to the gate in accordance with this Division.

Maximum penalty: 10 penalty units.

(2) A person who opens a public gate must cause it to be closed again immediately after it has been used.

Maximum penalty: 10 penalty units.

(3) A person who fails to cause a public gate to be closed is liable for any loss or damage suffered by the occupier of the land adjoining the public road on which the gate is situated as a result of the gate having been left open.

133 Construction of by-pass around road gate

(1) An occupier of land adjoining an unfenced public road across which a public gate is situated at the point where the road intersects a boundary fence:

(a) must not, unless the appropriate roads authority so permits, and

(b) must, if the appropriate roads authority so requires,

construct a by-pass for vehicles at the intersection of the road with the boundary fence.

Maximum penalty: 10 penalty units.

(2) The roads authority may not permit or require the construction of a by-pass:

(a) if the by-pass is to be used in connection with a public gate across a main road, except with the concurrence of the RTA, and

(b) if the public gate is part of a rabbit proof, dog proof or marsupial proof fence, except with the concurrence of the local rural lands protection board.

(3) A by-pass is to consist of:

(a) a ramp to allow vehicles to be driven over the top of the boundary fence, or

(b) a cattle grid or sheep grid located beside the gate,

and must be constructed in accordance with such specifications as may be approved by the roads authority.

(4) If the appropriate roads authority so requires, the person permitted or required to construct a by-pass:

(a) must construct the by-pass along the line of the road, and

(b) must re-locate the gate beside the by-pass.

Maximum penalty: 10 penalty units.

(5) The occupier for the time being of land to which a permit relates is taken to be the holder of the permit.

134 Notice board to be erected at by-pass

(1) The occupier of land on which a by-pass is constructed must ensure that:

(a) a notice, in the form required by the appropriate roads authority, is exhibited on a conspicuous notice board near each end of the by-pass, and

(b) both the by-pass and the notice are maintained in good condition.

Maximum penalty: 10 penalty units.

(2) A notice may prohibit vehicles exceeding a specified laden weight from being driven over the by-pass.

(3) If the appropriate roads authority requires a person to construct a by-pass, that

authority may contribute to the cost of construction and erection of the notices.

135 Closing of by-pass

(1) A by-pass may be closed and the notices relating to the by-pass may be removed:

- (a) if the public gate in connection with which the by-pass was constructed is removed, or
- (b) if the fence of which the by-pass forms part is made rabbit proof, dog proof or marsupial proof.

(2) A person who closes a by-pass:

- (a) must give notice of the closure to the appropriate roads authority before or immediately after the closure, and
- (b) must take such steps as the appropriate roads authority directs to ensure the safety of persons using the road.

136 Revocation of by-pass permit

(1) The roads authority may revoke a permit given with respect to a by-pass by means of a notice served on the holder of the permit.

(2) The occupier of the land the subject of the permit must, within the time specified in the notice:

- (a) remove the by-pass and its notices, and
- (b) take such steps as are specified in the notice to ensure the safety of persons using the road.

Maximum penalty: 10 penalty units.

137 Offences

(1) A person must not:

- (a) drive a vehicle over a by-pass in contravention of a notice displayed in connection with the by-pass, or
- (b) wilfully damage or remove a notice displayed in connection with a by-pass, or
- (c) wilfully obstruct or damage a by-pass.

Maximum penalty: 10 penalty units.

(2) A person who causes damage to a by-pass as a result of driving a vehicle over the by-pass in contravention of such a notice is liable for:

- (a) the cost of any repairs to the by-pass necessary as a result of the contravention, and
- (b) any loss or damage suffered by any other person as a result of the damage to the by-pass.

Division 3 Other works and structures

137A Definition

In this Division:

street vending consent means a consent under this Division that is subject to a condition referred to in section 139A.

138 Works and structures

(1) A person must not:

- (a) erect a structure or carry out a work in, on or over a public road, or
- (b) dig up or disturb the surface of a public road, or
- (c) remove or interfere with a structure, work or tree on a public road, or
- (d) pump water into a public road from any land adjoining the road, or

(e) connect a road (whether public or private) to a classified road, otherwise than with the consent of the appropriate roads authority.
Maximum penalty: 10 penalty units.

(2) A consent may not be given with respect to a classified road except with the concurrence of the RTA.

(3) If the applicant is a public authority, the roads authority and, in the case of a classified road, the RTA must consult with the applicant before deciding whether or not to grant consent or concurrence.

(4) This section applies to a roads authority and to any employee of a roads authority in the same way as it applies to any other person.

(5) This section applies despite the provisions of any other Act or law to the contrary, but does not apply to anything done under the provisions of the *Pipelines Act 1967* or under any other provision of an Act that expressly excludes the operation of this section.

139 Nature of consent

(1) A consent under this Division:

(a) may be granted on the roads authority's initiative or on the application of any person, and

(b) may be granted generally or for a particular case, and

(c) may relate to a specific structure, work or tree or to structures, works or trees of a specified class, and

(c1) in relation to integrated development within the meaning of section 91 of the *Environmental Planning and Assessment Act 1979*, is subject to Division 5 of Part 4 of that Act, and

(d) may be granted on such conditions as the appropriate roads authority thinks fit.

(2) In particular, a consent under this Division with respect to the construction of a utility service in, on or over a public road may require the service to be located:

(a) in such position as may be indicated in that regard in a plan of subdivision or other plan registered in the office of the Registrar-General with respect to the road, or

(b) in such other position as the roads authority may direct.

(3) In particular, a consent under this Division with respect to the erection of a structure may be granted subject to a condition that permits or prohibits the use of the structure for a specified purpose or purposes.

139A Street vending consents and charges in built-up areas

(1) A roads authority, in granting consent under this Division to the erection of a structure in, on or over a public road and located in a built-up area, may, without limiting section 139, impose conditions:

(a) permitting the use of the structure for the purpose of selling any article or service, and

(b) requiring payments in the nature of rent.

(2) The term of a street vending consent is to be such period (not exceeding 7 years) as is specified in the consent.

(3) For the purposes of this section, a structure is located in a built-up area if the structure is located in, on or over a part of a public road that is lit by street lighting located at intervals of not more than 100 metres for a distance of not less than 500 metres.

(4) Nothing in this section prevents a roads authority from granting a consent under

this Division that permits the use of a structure in, on or over a public road and not located in a built-up area for the purpose of selling any article or service.

139B Application of Environmental Planning and Assessment Act 1979

The granting of a consent under this Division that is subject to a condition of a kind referred to in section 139 (3) or 139A concerning the use of a structure does not affect the application (if any) of the *Environmental Planning and Assessment Act 1979*.

139C Revocation of street vending consents

(1) A roads authority may revoke a street vending consent if:

(a) a condition of the consent or a requirement under this Division is breached, or
(b) it is of the opinion that it is necessary to do so because of a change in the traffic or other road safety circumstances affecting the road.

(2) The roads authority may only revoke the street vending consent by notice in writing served on the holder of the consent.

139D Extension and transfer of street vending and other consents

(1) A roads authority may, at the end of the term of a street vending consent, extend the term of the consent for such further period (not exceeding 7 years) as is specified in the consent.

(2) An extension may be granted on the application of the holder of the consent.

(3) A roads authority may transfer a street vending consent or another consent under this Division permitting the erection and use of a structure for a purpose to a person other than the holder of the consent.

(4) A transfer may be granted on the application of the holder of the consent or of another person made with the holder's consent.

(5) A roads authority may impose a condition as to payments in the nature of rent when it extends or transfers a street vending consent.

(6) Section 139 applies to a consent extended or transferred under this section.

139E Fresh consents

(1) A roads authority may grant a fresh street vending consent or other consent under this Division in respect of a structure if the previous consent is revoked, expires or otherwise lapses.

(2) The consent granted may be granted on the roads authority's initiative or on the application of any person.

(3) The consent granted may be a street vending consent or other consent even though the previous consent was of a different kind.

139F Matters to be taken into account

(1) When considering whether to grant, extend or transfer a street vending consent, or other consent under this Division permitting the use of a structure in, on or over a public road not in a built-up area, for the purpose of selling any article or service, the roads authority must comply with guidelines relating to street vending jointly issued by the RTA and the Department of Local Government.

(2) A street vending consent may not be granted if a structure is subject to a lease under section 149.

140 Revocation of consents

A roads authority may at any time and for any reason revoke a consent under this

Division (other than a street vending consent) by notice in writing served on the holder of the consent.

141 Effect of consent

While a consent under this Division is in force, the taking of action in accordance with the consent is taken not to constitute a public nuisance and does not give rise to an offence against this or any other Act.

142 Maintenance of works and structures

(1) A person who has a right to the control, use or benefit of a structure or work in, on or over a public road:

- (a) must maintain the structure or work in a satisfactory state of repair, and
- (b) in the case of a structure (such as a grating or inspection cover) located on the surface of the road, must ensure that the structure is kept flush with the surrounding road surface and that the structure and surrounding road surface are so maintained as to facilitate the smooth passage of traffic along the road, and the person is, by this section, empowered to do so accordingly.

Maximum penalty: 30 penalty units.

(2) Subsection (1) applies to all structures and works in, on or over a public road, including structures and works for which there is no consent in force under this Division.

(3) Subsection (1) does not apply to a person whose right to the control, use or benefit of a structure or work consists merely of a right of passage that the person has as a member of the public or a right of access that the person has as the owner of adjoining land.

(4) If:

- (a) a roads authority has granted a consent under this Division to the doing of anything, and
- (b) that thing has been or is being done otherwise than in accordance with the consent,

the roads authority may direct the holder of the consent to take specified action to remedy any damage arising from the doing of that thing otherwise than in accordance with the consent.

143 Roads authority may use public road in exercise of functions

Nothing in this Division prevents a roads authority from using a public road in the exercise of a function conferred by this Act so long as the function is exercised in a way that will not unduly interfere with the rights of passage and access that exist with respect to the public road.

Division 4 Road events

144 Permits for road events

(1) A roads authority may grant a permit to any person to conduct a road event on a public road.

(2) A permit may not be granted with respect to a classified road except with the consent of the RTA.

(3) A permit may not be granted with respect to an activity for which an approval is required under section 40 of the *Road Transport (Safety and Traffic Management)*

Act 1999 unless such an approval is in force.

.....

Division 2 Short-term leases of unused public roads

153 Short-term leases of unused public roads

(1) A roads authority may lease land comprising a public road (other than a Crown road) to the owner or lessee of land adjoining the public road if, in its opinion, the road is not being used by the public.

(2) However, a lease may not be granted under this Division with respect to land that has been acquired by the RTA under Division 3 of Part 12 (being land that forms part of a classified road) except by the RTA.

(3) A lease granted under this Division may be terminated by the roads authority at any time and for any reason.

154 Public notice to be given of proposed lease

(1) Before granting a lease under this Division, the roads authority must cause notice of the proposed lease:

- (a) to be published in a local newspaper, and
- (b) to be served on the owner of each parcel of land adjoining the length of public road concerned.

(2) The notice:

- (a) must identify the public road concerned, and
- (b) must state that any person is entitled to make submissions to the roads authority with respect to the proposed lease, and
- (c) must indicate the manner in which, and the period (being at least 28 days) within which, any such submission should be made.

155 Public submissions

Any person may make submissions to the roads authority with respect to the proposed lease.

156 Decision on proposed lease

(1) After considering any submissions that have been duly made with respect to the proposed lease, the roads authority may grant the lease, either with or without alteration, or may refuse to grant the lease.

(2) If the roads authority grants a lease, the roads authority must cause notice of that fact to be published in a local newspaper.

157 Special provisions with respect to short-term leases

(1) The term of a lease, together with any option to renew, must not exceed:

- (a) except as provided by paragraph (b), 5 years, or
- (b) in the case of a lease of land that has been acquired by the roads authority under Division 3 of Part 12, 10 years.

(2) A person must not erect any structure on land the subject of a lease under this Division otherwise than in accordance with the consent of the roads authority.
Maximum penalty: 10 penalty units.

(3) Such a consent may not be given unless the roads authority is satisfied that the proposed structure comprises a fence or a temporary structure of a kind that can

easily be demolished or removed.

.....

Division 3 Enforcement of certain directions

237 Manner and form in which directions to be given

- (1) A direction under this Act must be in writing, may be served personally or by post and may be varied or revoked by a further direction in writing so served.
- (2) A direction under section 93, 95, 103, 104 or 107 may instead be given orally in cases of emergency.
- (3) A direction under section 230 may be given orally.

238 Roads authority may give effect to direction and recover costs

- (1) A roads authority may take such action as is necessary to give effect to a direction under this Act if the direction is not complied with in accordance with its terms.
- (2) The costs incurred by a roads authority in taking action under this section are recoverable from the person to whom the direction was given, as a debt, in a court of competent jurisdiction.
- (3) The costs incurred by an authorised officer in exercising any function under Division 2 as a result of the failure of any person to comply with a direction under that Division with respect to a vehicle are recoverable by the appropriate roads authority from the owner of the vehicle, as a debt, in a court of competent jurisdiction.
- (4) Nothing in this section authorises a roads authority to recover an amount greater than that necessary to give effect to the direction.

Division 4 Miscellaneous offences

239 Failure to comply with directions

A person must not, without reasonable excuse, fail to comply with a direction given to the person under this Act.
Maximum penalty: 30 penalty units (in the case of an offence arising under Division 4 of Part 7 or Division 2 of this Part) and 10 penalty units (in any other case).

Roads (General) Regulation 2000

.....

5 Temporary closing of road

- (1) A roads authority must give at least 7 days notice of its intention to close a public road in the exercise of its functions under Part 8 of the Act:
 - (a) by means of a notice published in a local newspaper, and
 - (b) by means of conspicuous notices erected along the road.
- (2) No such notice is necessary in the case of an emergency.

.....

APPENDIX B – SECTION 138 AGREEMENT

This page intentionally blank, see following pages for Section 138 Agreement.



KYOGLÉ COUNCIL
SECTION 138 AGREEMENT
'WORKS IN ROAD RESERVE'

(FOR USE OF A COUNCIL ROAD RESERVE)

This agreement relates to any construction work or activity (*such as unloading materials*) that will be carried out within Council's road reserve i.e any part of a public road including the verge and footpath area.

**Development
Application No.**

Applicants Name

Applicants Address

**Applicants Telephone
No.**

**General Manager
Kyogle Council
PO Box 11
KYOGLÉ NSW 2474**

**PH: 02 66320200
FX: 02 66322632**

Applicable Fees:	
Approval/Inspection Fee	\$ inc GST
Road Closure Advertising Fee	\$ inc
Supply Standard Traffic Control Plan	\$ inc GST
Assessed Fee:	
Job No:	11221-005
Receipt No:	_____
Date Paid:	_____
Forward to:	Engineer Asset Services

GUIDELINES FOR COMPLETION

SECTION 138 AGREEMENT FOR USE OF A COUNCIL ROAD RESERVE – ‘WORKS IN ROAD’

SCHEDULE 1

Enter the name of the road on which the activity will be taking place.

SCHEDULE 2

Enter the full property details such as Lot, DP and street number.

SCHEDULE 3

Description of work: The applicant is to specify the type of work to be carried out within the road reserve, for example: (operation of crane to lift trusses onto building site, construction of a driveway or any other proposed activity.)

SCHEDULE 4

- a. Details of Public Liability Insurance must be provided at the time of application. This means a ‘Certificate of Currency’ from your Insurance Company or Broker noting Kyogle Council as an interested party and confirming the following:
 - sum insured
 - that cover extends to work in a Public Road
 - expiry date of the policy
- b. A Safety Management Plan must be provided with the application. A copy of the guidelines is attached and it is strongly recommended that the Applicant obtain a copy of Workcover’s Subby Pack and Small Business Starter Kit. Whilst a generic plan may be lodged with Council a site specific Safety Management Plan must be provided with each application.
- c. An Environmental Management Plan must be provided with the application. A copy of the guidelines is attached. Whilst a generic plan may be lodged with Council a site specific Environmental Management Plan must be provided with each application.

SCHEDULE 5

Enter the anticipated start date of the works.

SCHEDULE 6

Conditions relating to the Section 138 Agreement to be read in full.

Failure to provide these details will result in extended delays in determining the application and subsequent approval.

NOTES:

1. If this Section 138 relates to the installation of a vehicular access, an application for a Vehicular Access Permit must be made and approved prior to making application to conduct works. Refer Council’s Property Access and Addressing Management Plan.
2. If this Section 138 relates to the installation of a Public Gate and/or Grid, an application for a Public Gate Permit must be made and approved prior to making application to conduct works. Refer Council’s Public Gate and Motor Bypass (Cattle Grid) Management Plan.
3. If this Section 138 relates to construction or upgrade of Council owned assets such as roads, drainage, water, sewerage, footpaths, etc, engineering plans must be lodged and approved prior to making application to conduct works. Refer Council’s Road Network Management Plan.

AGREEMENT FOR USE OF A COUNCIL ROAD RESERVE

‘WORKS IN ROAD’

THIS AGREEMENT made the _____ day of _____ 2003.

BETWEEN (hereinafter called the Applicant) of the one part

(Name)

(Address)

AND **KYOGLE COUNCIL** (hereinafter called the Council) of the other part.

WHEREAS

The Applicant desires to use the public road specified in the first Schedule hereto to benefit the property specified in the Second Schedule hereto.

AND WHEREAS

Council has agreed to issue a consent for such use the Applicant entering into this Agreement upon the terms and conditions hereinafter contained.

NOW IT IS HEREBY AGREED as follows:

- 1 The Council pursuant to the provision of Part 9 Division 3 Sections 138 to 143 of the Road Act 1993 hereby grants permission to the applicant to carry out the works or erect structures as specified in Schedule Three hereto.
- 2 The applicant agrees to:
 - a Carry out works or erect the structures at the applicants own cost in conformity with ordinary good practice and as more particularly specified in Schedule Six hereto together with any further notices issued in writing by the Director of Technical Services or his representative.
 - b Carry out the work or erect the structures as expediently as practicable and with due regard to convenience, safety and the rights of the public.
 - c To observe and fulfil any reasonable requests in respect of maintenance of the said works or structures and in particular any requirements specified in any notices in writing addressed to the Applicant and to comply with any such requirements within the time specified in such notice.

- d
 - i That the Applicant will at all times indemnify and keep indemnified the council from and against all actions suits proceedings losses costs damages charges claims and demands in any way arising out of or by reason of anything done or omitted to be done by the Applicant in respect of the construction renewal repair and maintenance of the work or use thereof or by reason of the Council having entered into this Agreement or having approved or directed or assented to anything done or purported to be done by the Applicant under this Agreement and that in respect of any matter covered by this indemnity the Council shall be at liberty to pay satisfy defend compromise or settle any claim action or other proceedings which may be made threatened instituted commenced or prosecuted against the Council and any amount paid by the Council in accordance with this clause shall be repaid to him or it by the Applicant.
 - ii To extend its Public Risk Insurance Policy to cover the Council. Policy cover of at least \$10,000,000, evidence of such policy, its extension to cover the Council and is to be produced on request. Details of the current Policy are to be set out in Schedule 4.
- e
 - i That should the applicant fail to comply with the provisions of this Deed or any requirement of the Council as herein provided then any such breach may be made good by the Council and the cost involved or the damage suffered recovered from the Applicant by the Council as a debt due and unpaid without prejudice to the right of the Council to terminate the permission granted hereby.
 - ii In the performance of any alteration to the work the Applicant shall observe all requirements imposed by any statute regulation or ordinance or otherwise imposed by any statutory or other authority.
- f
 - i To make enquiry, search investigation into the existence and location of public utility services in particular Telecom cables gas electricity water sewer and drainage lines and other private services in particular irrigation pump line and communication lines and to carry out work in such a manner so as to cause no damage to the existing services.
 - ii To make good repair or arrange repair of any damage caused to services or other private property so caused in the execution of the works and bear the costs of such repairs.

3 If the Applicant shall fail to perform any obligation imposed on it under this agreement or any work required by or the Council thereunder it shall be lawful for the Council immediately thereupon to determine the permission hereby granted and upon the expiration or the sooner determination of this permission or an extension thereof the Applicant shall immediately and in such manner as the Council may direct remove and take away as speedily as possible the work insofar as the same may encroach upon or in any way affect the public way and shall make good all damage done to the public way by such removal and in the course of so doing shall pay the Council the cost of making good any such damage.

4 And it is further agreed by the parties hereto that nothing in this deed shall be deemed to:

- i prejudice or affect the rights of the public to free passage upon or along the said road.
- ii authorise any nuisance to or permanent obstruction of the road or public places, or

- iii confer upon the Applicant exclusive right or title or the sole use of that part of the work within the road boundary,
- iv In any way restrict or limit the powers of the Council in respect of the work and construction.

(SEE ATTACHED SCHEDULES)

D A No: _____

APPLICANT: _____

SCHEDULES

SCHEDULE 1
(Description of the subject public road) _____

SCHEDULE 2
(Description of benefiting property, Lot, DP and street numbers) _____

SCHEDULE 3
(Description of Work on Road Reserve) _____

SCHEDULE 4
(Insurances\Safety and Environmental Management Plans)

Public Liability Insurance: The Contractor and all sub-Contractors employed from time to time in relation to the work must have in place insurance for their respective rights and interests to cover their liabilities to third parties (as extended to cover subject works for the person doing the works in the Road Reserve). These policy/policies must note the interests of Council. The policy shall contain a cross liability clause and shall have a limit of indemnity of not less than the amount indicated for any one occurrence, but shall be unlimited in the aggregate. <i>(A copy of the policy must be provided).</i>	Amount of Cover	
	Insurance Company	
	Policy Number	
	Expiry Date	

Safety Management Plan
(Please refer to guidelines attached) _____

Environmental Management Plan
(Please refer to guidelines attached) _____

SCHEDULE 5
(Anticipated Commencement Date of Work) _____

SCHEDULE 6

CONDITIONS OF APPROVAL FOR USE OF A COUNCIL ROAD RESERVE APPLICATION - WORKS IN ROAD RESERVE

- 1 The works shall be carried out in accordance with Council's Engineering Specifications, Development Control Plans, and Design & Construction Specifications.
- 2 The Applicant shall provide a copy of the plans and specifications to be approved by Kyogle Council prior to the works commencing.
- 3 A Traffic Control Plan for traffic control at the work site must be submitted and approved by Council prior to work commencing. The Traffic Control Plan shall be verified by an authorised person in accordance with the RTA Manual "Traffic Control at Worksites". The site of the work shall be adequately barricaded, or otherwise protected to ensure the safety of the travelling public, including pedestrians. Adequate advance warning signs shall be erected in accordance with the "Traffic Control Plan" and maintained during the course of the work. All traffic controllers shall have the necessary accreditation.
- 4 The Applicant shall inquire, search, investigate the location and depth of any public utility service in particular Telecom cables, gas, electricity, water, sewer and stormwater and other private services such as irrigation pump lines before any works commence on site and ensure that no damage or conflict shall result. The applicant shall be liable for any damage to these services.
- 5 Work shall only be carried out during daylight hours, 7.00 am – 6.00 pm weekdays, 8.00 am – 6.00 pm Saturday and no trench within the road reserve shall be left open or unfenced and signposted after dark.
- 6 Excavation works shall be carried out in a manner that will ensure safe passage of vehicles at all times.
- 7 Council shall be reimbursed by the applicant/beneficiary, when requested, for any expenses incurred in restoring the road pavement, or other sections of the excavation site, within the road reservation.
- 8 The agreement cannot be assigned or transferred to another person
- 9 Any works on a Public Road Reserve are classified as High Risk Construction as defined in the OH&S Act 2000. All works is to be carried out in accordance with this Act and OH&S Regulation 2001.
- 10 For the purposes of the OH&S Act 2000 "the applicant" will be the Principal Contractor.
- 11 Appropriate Safety Management Plan and Environment Management Plan to be submitted to Council prior to the commencement of any works.
- 12 The applicant is to ensure that the contractor and sub-contractors are registered and appropriately insured for working on a public road.
- 13 The applicant must advise Council's Engineer Asset Services on (02) 66 320 228 at least 24 hours prior to work commencing in road.

IN WITNESS WHEREOF of the parties hereto have hereunto set their hands on the day and year first above written.

SIGNED by the

said.....)

Name

.....
Signature

in the presence of

.....)

Name of Witness

.....
Signature

SIGNED FOR AND ON BEHALF OF KYOGLE COUNCIL:

said.....)

Name for General Manager

in the presence of

.....)

Name of Witness

.....
Signature

APPENDIX C – OHS&R MANAGEMENT PLAN GUIDELINES

Preparation Of Project Occupational Health Safety & Rehabilitation Management Plan

The Contractor (service provider) is to prepare and submit a project based OHS&R Management Plan to cover all activities included in the contract.

The following key system elements need to be addressed in the preparation of the plan (OHS&R) Management System Guidelines Ed 3, NSW Govt);

1	Management responsibility
2	Subcontracting and purchasing
3	Process control
4	Inspection and testing
5	Control of OHS & R issues
6	Corrective action
7	Handling, storage, packaging and delivery
8	Training
9	OHS&R records
10	Design
11	internal OHS&R reviews

1 MANAGEMENT RESPONSIBILITY

This element is about defining the organisation policies and objectives for OHS&R and commitment to it; identifying responsibilities for OHS&R; and providing the resources needed for verification.

Some specific OHS&R issues for which responsibilities and authorities need to be defined, in both job descriptions and documented procedures are listed below.

(This 's not necessarily a complete list)

- defining the organisations OHS&R policies objectives
- identifying personnel responsible and qualified for OHS&R matters
- identifying internal audit requirements
- allowing for appropriate time and cost requirements to implement the organisations safety system
- managing compliance with OHS&R legislation, regulations, standards and codes
- managing compliance of the organisations OHS&R management system
- managing OHS&R design issues
- acquiring and disseminating OHS&R information
- consultation with personnel on OHS&R issues
- consultation with OHS&R workplace committees
- planning and conducting safety training, including induction, task training and refresher training
- developing and implementing emergency procedures
- assessing subcontractors' ability to comply with OHS&R requirements
- ensuring compliance with safe working rules
- identifying hazards and assessing risk
- preparing Safe Work Method Statements
- verifying (by Inspections and tests) that work areas, work methods, materials, plant and equipment comply with safety legislation, regulations, standards and codes

- quarantining unsafe work areas, materials, plant and equipment
- reporting incidents and accidents and collating incident, accident and injury statistics
- investigating incidents and accidents and initiating corrective (preventative) actions; and
- injury management programs and rehabilitation of injured personnel.

2 SUBCONTRACTING AND PURCHASING

This element is about ensuring that all materials, equipment, plant and services purchased or hired and all subcontractors conform to specified OHS&R standards.

3 PROCESS CONTROL

This element is about identifying OHS&R risks and properly planning the work process to control those risks. It also covers ancillary measures such as temporary works, emergency procedures, plant maintenance and preventative and protective measures.

General site safety procedures must be in force on every site. These include rules for protective clothing, safe access and exits, traffic and plant movements, and personnel movements (including the general public), The procedures must be documented and appropriately communicated to people working on site.

Minimum process control documentation for a Site-specific Safety Management Plan

Accordingly, service providers must document.

- Safe Work Method Statements
- the method for identifying, assessing and managing OHS&R risks
- how it is planned to minimise the risk of incidents occurring, and thus aim to ensure compliance with relevant OHS&R legislation, standards and codes
- general site safety procedures
- emergency procedures
- training including induction and work activity.

Service providers must prepare Safe Work Method Statements for ALL work activities assessed as having a safety risk.

Minimum requirements for Safe Work Method Statements

1. Safe Work Method Statements must:

- be on organisations letterhead and show the name and registered office address of the organisation
- show the signature of a senior management representative of that organisation and the date signed

2. Safe Work Method Statements must at least include:

- a description of the work to be undertaken
- the step-by-step sequence involved in doing the work
- the potential hazards associated with the work and with each step of the work
- the safety controls that will be in place to minimise these hazards
- all precautions to be taken to protect health and safety
- till health and safety instructions to be given to persons involved with the work

- identification of health and safety legislation, codes or standards applicable to the work, and where these are kept
- the names and qualifications of those who will supervise the work inspect and approve work areas, work methods, protective measures, plant, equipment and power tools
- a description of what training is given to people involved with the work
- the names of those who will be or have been trained in the work activities described in the Safe Work Method Statements, and the names and qualifications of those responsible for training them
- Identification of the plant and equipment that will most likely be used on site eg. ladders, scaffolds, grinders, electrical leads, welding machines, fire extinguishers
- details of the inspection and maintenance checks that will be or have been carried out on the equipment listed,

4 INSPECTION AND TESTING

This element is about establishing procedures for planning and conducting OHS&R inspections, testing and monitoring of work sites, equipment and processes, as well as of incoming products and materials.

5 CONTROL OF OHS&R ISSUES

This element is about establishing procedures to control use of products, materials, equipment or work practices which do not meet OHS&R standards, and to ensure rehabilitation programs are in place.

Control of issues involves taking action to ensure that:

- incident/accident reporting procedures are applied
- any non-compliance is promptly detected, identified and documented
- there are no unsafe work practices or unsafe areas
- non-conforming materials are not used or installed
- appropriate parts of the organisation and relevant authorities such as Workcover NSW are advised; and
- irregularities are effectively resolved.

6 CORRECTIVE ACTION

This element is about the process of ensuring that OHS&R issues are appropriately addressed and similar issues do not recur.

7 HANDLING STORAGE, PACKAGING AND DELIVERY

This element is about establishing procedures to ensure compliance with legislative and standard requirements for handling, storage, packaging and delivery of products and materials.

8 TRAINING

This element is about establishing procedures and allocating resources to identify and provide for the training needs of personnel on projects

Contractors are therefore required to:

- identify the OHS&R training needs of management, supervisors, and workers on the project, ensure that all personnel undergo induction and necessary task training to conform with OHS&R standards; and
- maintain appropriate records of OHS&R training provided to personnel on the project and the construction site.

On construction sites, judgement and personal responsibility are just as important as the Site Safety Rules. A training program will need to build understanding and responsible attitudes as well as knowledge about OHS&R issues, hazards and procedures.

Induction training must be provided to all personnel on site. Before any person carries out construction work they must be provided with OH&S induction training in:

- general construction work health and generic safety
- site-specific health and safety and Should exceed general induction
- work activity based safety.

Induction training is important on changing work sites where new personnel and new work activities are constantly being introduced.

9 OCCUPATIONAL HEALTH, SAFETY & REHABILITATION RECORDS

This element is about establishing procedures for the identification, filing, retrieval and retention of OHS&R records.

Records provide evidence of compliance, not only with the OHS&R management system and plans, but also with standards and legislation.

These records would include:

- details of qualifications held by individuals
- inspections and tests reports
- audit reports
- Internal review reports
- reports of accidents or safety incidents
- minutes of workplace OHS&R meetings
- incident analyses
- accident statistics: lost time, frequency rates and duration rates as covered by the relevant Australian Standard
- minutes of management review meetings
- evidence of action taken as a result of such meetings or events
- induction and training records
- safety equipment records
- details of any dangerous goods or hazardous substances held,. their quantities and locations; and
- design review records

This is not necessarily a complete list; other records may also be required

10 DESIGN

This element is included to ensure that adequate consideration is given to OHS&R issues during the design process.

11 INTERNAL OCCUPATIONAL HEALTH, SAFETY & REHABILITATION REVIEWS

This element relates to establishing procedures for planning and undertaking internal reviews to verify that on-site OHS&R processes match the organisations stated plans.

APPENDIX D – ENVIRONMENTAL MANAGEMENT PLAN GUIDELINES

Preparation Of An Environmental Management Plan

The Contractor (service provider) Is to prepare and submit an Environmental Management Plan (EMP) covering all aspects of the contract.

The following information outlines the need for an EMP and sets out some of the requirements (Environmental Management Guidelines, NSW Govt):

An Environmental Management Plan (EMP) is a site-specific plan developed to ensure that all contractors and sub-contractors comply with the environmental conditions of approval for the project and that the environmental risks are properly managed.

In some projects there are no environmental impact assessment undertakings, consent conditions or pollution control approvals. Some contractors may even not be aware of any statutory obligations attached to their activities on the project. In determining environmental aspects and impacts, a contractor needs to consider if any of the organisation's activities, products or services relevant to the project will have any effect on air, water, land or waste.

In the simplest of organisations this may entail the asking of basic, questions such as:

AIR: What sort of emissions to air will the organisation be responsible for: noise? smoke? exhaust fumes?
WATER: How much water will the organisation use? Where will It go? Will anything be discharged or spilled into drains or watercourses (rivers, streams, ponds, dams etc)?
LAND: Do any of the organisation's activities, products or services affect the soil, local wildlife or plants?
WASTE: How much material or energy does the organisation waste?

In asking these questions the contractor should take into account reasonably anticipated events such as spillages, plant breakdowns or inclement weather which could affect its day to day activities.

Having identified the potential environmental aspects and impacts, the contractor must then determine how the organisation is to manage these issues - for example *How are we going to wash our paint brushes? How will we control soil erosion if it rains?*

All of this must be documented and communicated so that all personnel on the project will know:

- what environmental risks are involved in the project
- what is the plan to manage these risks
- who is responsible for ensuring that the plans are followed
- what to do and who to contact if there is an accident.

What elements must be included in an EMP?

The scope of an EMP may vary, depending on the scale and environmental impact of the project.

FOR ALL PROJECTS

All EMP's should include at least the following four elements;

1. *Commitment And Policy*

Objectives of the EMP,

2. *PLANNING*

A listing of the environmental aspects and impacts associated with the work. including:

- specific undertakings arising from the environmental impact assessment
- consent conditions
- pollution control approvals and any conditions attached to the approvals
- statutory obligations: and
- environmental risks,

3. *Implementation*

Documentation of the measures to be taken to manage the identified aspects and impacts. These measures are subject to approval by the responsible agency and in compliance with the tender documents.

4. *Responsibilities*

and
A clear indication of the respective environmental responsibilities of the contractor
sub-contractors

APPENDIX E – APPLICATION TO CONDUCT WORKS IN ROAD RESERVE

All Communications to be addressed to:
 Office:
The General Manager
Kyogle Council
PO Box 11
Kyogle NSW 2474
632

Administrative

Stratheden Street
Kyogle NSW 2474
Telephone: 66 320 221
Facsimile: 66 322

APPLICATION TO CONDUCT MINOR WORKS WITHIN THE ROAD RESERVE

Applicant:.....

Address:.....

Phone No:Permit Number: (if applicable).....

LOCATION OF WORKS;

Road Name:.....

Description of work area: (eg “western side of road fronting property described below”)

.....

Plan Attached: yes / no Description of adjoining land: Lot/s.....DP.....

Rural Address/s:.....

DESCRIPTON OF WORKS;

Which of the following works do you wish to undertake;

Description of works	Yes/No
Mowing of roadside area using tractor mounted device	
Maintenance of Public Gate and Bypass (Cattle Grid) not involving works on the trafficable road	
Maintenance of Property Access not involving works on the trafficable surface	
Minor tree lopping and/or removal	
Erection of minor private structure	
Road Crossing by under-bore	
Fencing road reserve boundary where entry onto road reserve is required	

Other: Please Describe.....

.....

DURATION OF WORKS;

Proposed Commencement Date and Time:/...../..... at:.....pm/am

Proposed Completion Date and Time:/...../..... at:.....pm/am

Additional Information:.....

Note: Works are only to be conducted within daylight between the hours of 7:00am to 6:00pm weekdays, and 8:00am to 6:00pm weekends.

APPLICATION CHECKLIST;

Question	Answer (Yes/No)	Action if “No”	Action if “Yes”
Does the proposed works require a Temporary Road Closure?		Nil	You will need to make a formal written application to Council with the appropriate fees and the works will require a Section 138 Agreement.
Have you provided Council at least 14 days notification prior to the proposed date of commencement of works?		You will need to delay the proposed commencement date to allow for the notification period.	Nil
Do you have public liability insurance in place that meets the following requirements; <ul style="list-style-type: none"> • Minimum coverage of \$10,000,000, and • Kyogle Council are listed as an interested party, and • Coverage includes the specific activity you propose to conduct 		You are not able to conduct the proposed works.	Provide a copy of the certificate of currency with this application, and a letter from your insurance company stating you are covered for the specific activity
Do you have appropriate Safe Work Method Statements for the proposed works?		Contact Council for a copy of their standard Safe Work Method Statements if available. Otherwise you are not able to conduct the proposed works.	Ensure Safe Work Method Statements are provided to Council with this application, kept on site during the works, and followed during works.
Do you have an appropriate Traffic Control Plan or Traffic Management Plan prepared for the proposed works?		Contact Council for a copy a standard Traffic Control Plan if available. Otherwise you are not able to	Traffic Control Plan to be used must be submitted to Council with this application and signage must be

		conduct the proposed works.	in place during the course of works.
Have you carried out a written risk assessment for the work for this particular site?		Please undertake a risk assessment. (Standard Risk Assessment forms can be provided by Council)	Keep a copy of the Risk Assessment form for your records and reference on site.
Are your staff credited with the following induction training; <ul style="list-style-type: none"> • General..... • Work Activity..... 		Staff to be inducted in "general" and "work activity" requirements before starting work on site.	Nil
Do you have records of all relevant certificates of accreditations for staff that will be on site? (eg plant operator, traffic control etc where required)		Please organise for records to be developed.	Please have these available on site for reference as required.
Are any of your staff qualified First Aid Attendants?		Nil	Please provide names; <ul style="list-style-type: none"> • • •
Do you have written Emergency Procedures and Emergency Equipment available for your staff?		Please develop specific procedures for your work activities and provide necessary equipment.	Please provide a copy of procedures to Council and please list all emergency equipment. (use separate sheet if necessary)
Are fire extinguishers inspected and tagged?		Please arrange for this to be done.	Nil
Are you bringing plant items onto the site?		Nil	Please list items. (use separate sheet if necessary)
Are all plant items regularly; <ul style="list-style-type: none"> • serviced..... And checked for; <ul style="list-style-type: none"> • safe operation..... • safety equipment..... • Noise/ exhaust emissions... 		Please arrange for these to occur. (Plant Safety Checklist is available for use if required)	Please provide details of relevant systems to Project Engineer.
Are you bringing power tools or electrical leads onto the site?		Nil	Please list items. (use separate sheet if necessary)
Are your electrical tools and leads inspected and tagged?		If no, equipment is not to be brought on site until inspected and tagged.	Nil
Are you bringing lifting slings or chains onto the site?		Nil	Please list items. (use separate sheet if necessary).
Are your slings and chains tagged and rated, and are they checked by a qualified dogger/rigger/crane chaser each month?		If no, equipment is not to be brought on site until requirements are met.	Nil
Are you bringing ANY hazardous substances or dangerous goods onto		Nil	Please list items and quantities. (use

the site?			separate sheet if necessary)
Do you have Material Data Safety Sheets (MSDS) for all chemicals and other hazardous substances?		Please provide them prior to starting work.	Please provide a copy to Council and keep copies on site.

I understand that the application and approval (if granted) will be subject to the conditions set out below.

- ❖ Provision of adequate description and details for consideration of this application.
- ❖ The applicant indemnifies Council against any Claims made against Council and which arises directly from the acts or omissions of the applicant, its employees, agents, contractors, and/ or invitees on Council's property.
"Claims" means all claims, demands, proceedings, litigation, or other action a party is entitled to bring in relation to all losses (including profits & consequential losses), damages, costs, expenses, fees and charges of any nature whatsoever suffered or incurred by that party.
- ❖ During works the applicant will;
 - Accept responsibility and indemnify Council, as per above, for damage to power lines, water mains, telephone/ communication lines, road surfaces or other services,
 - Undertake all work in compliance with the Roads Act 1993 and Occupational Health & Safety legislation in force in NSW at the time.
 - Ensure signage is erected in accordance with the appropriate Traffic Control Plan.
 - Ensure all plant are operated and maintained in a safe working manner.
 - Keep copies of the appropriate Safe Work Method Statement/s on site at all times and ensure these are followed.

Declaration;

I have read and understand the conditions set out above and wish to proceed with my application under those conditions.

.....
Signature of Applicant

.....
Date

APPENDIX F – NOT USED

APPENDIX G – NOT USED

APPENDIX H – STANDARD ROAD CROSSING

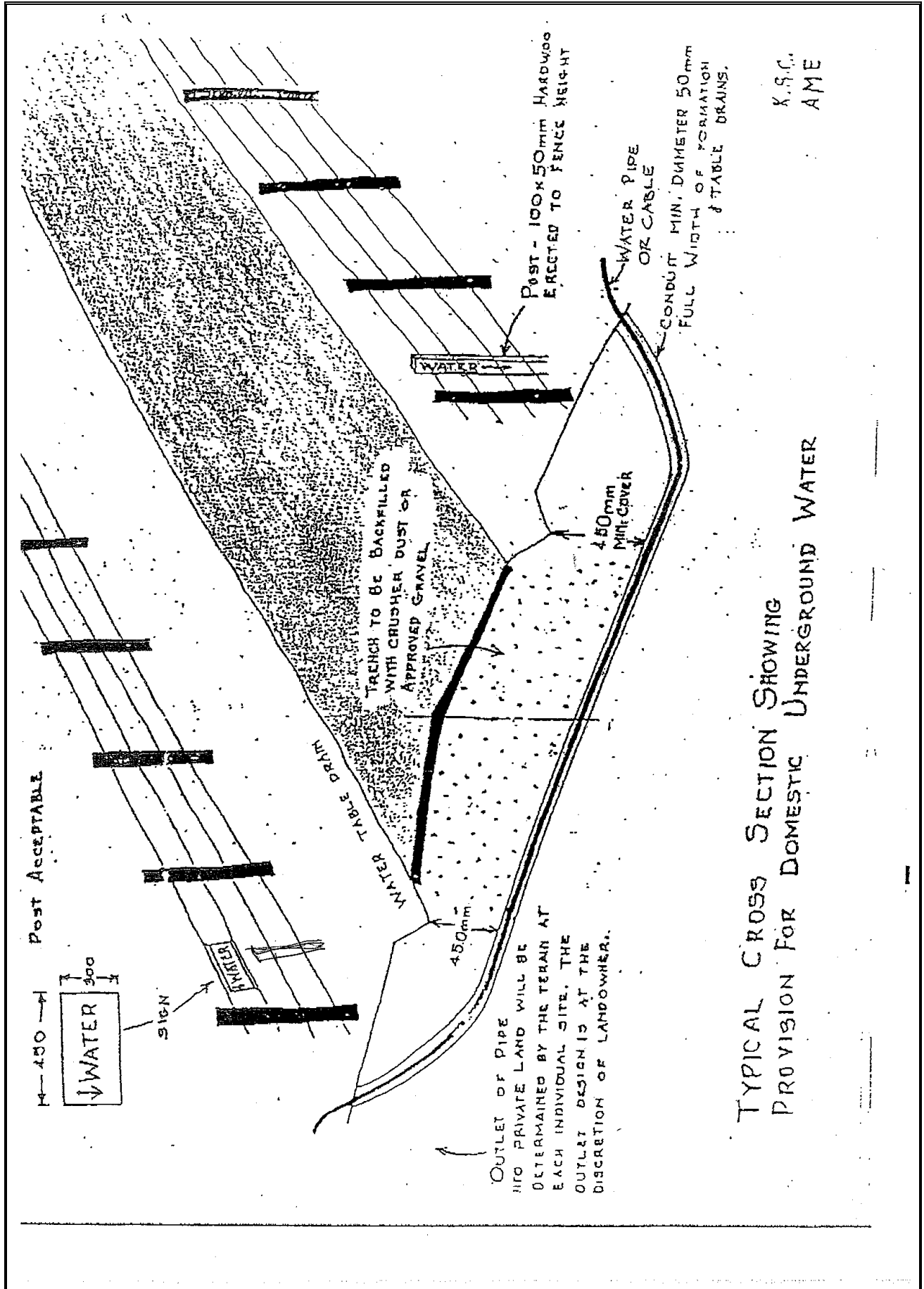

TYPICAL CROSS SECTION SHOWING PROVISION FOR DOMESTIC UNDERGROUND WATER

K.S.C.
AME

APPENDIX I – NON-COMPLYING WORKS INSPECTION FORM

Project Description:
Location of Works:
Inspecting Officer: _____ **Date:** _____
Contractors Representative: _____

1. Description of Problem

Does it arise from: *Audit* *System Review* *Staff Observation* *Customer Request*
Random Inspection *Other* (*Details*):

Notified by: _____ Position: _____ (date)

2. Immediate Fix to Contain or Rectify Problem Situation

Action by: _____ Date completed: _____
 Restriction on project work, or Stop Work Order issued pending long term fix? Yes/No
 Authorisation by Director Technical Services: _____ (date)

3. Underlying Cause of Problem

Assessed by: _____ (date)

4. Long Term Fix to Address Problem Action by Complete by

Approved by: _____ Director Technical Services _____ (date)

5. Close-out Report

Documents amended and authorised? Yes/No
 Documents issued and on site? Yes/No
 Is long term fix effective? Yes/No

Comments:

Reviewed by: _____ Director Technical Services _____ (date)

APPENDIX J – STANDARD DRAWINGS FOR ROADSIDE FENCING



- 1 Wire shall be 4.0 mm dia. galvanised or 2.5 mm dia. galvanised barbed wire as directed. Wires shall be fastened to posts as shown or alternatively 30 mm dia. auger holes may be bored in timber posts for barbed wire. All posts shall have 12 mm dia. holes for plain wires.
- 2 Sawn hardwood posts shall be 150 mm by 100 mm.
- 3 Split hardwood posts shall be four-sided with no average cross sectional dimension less than 100 mm and no outside dimension less than 65 mm. Cross sectional area shall not be less than 18,000 square millimetres.
- 4 Cypress pine posts shall be round and shall have a minimum diameter at the small end of 140 mm.
- 5 Concrete posts shall be either reinforced or prestressed concrete, the design of which shall be subject to the approval of the Engineer (See M.R. Form No 141).
- 6 Fence shall be strained at intervals not exceeding 90 metres.
- 7 For method of erecting posts in earth or rock (See M.R. Form No 141).

All dimensions are in millimetres unless otherwise shown.

DEPARTMENT OF MAIN ROADS, NSW	
POST AND WIRE CATTLE FENCING	
M.R. DRAWING No SD1705	REVISED JULY 11

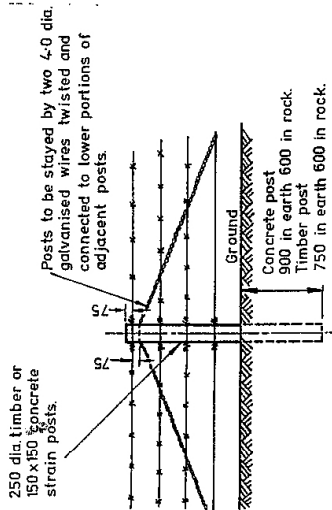

STRAIN POST, INTERMEDIATE

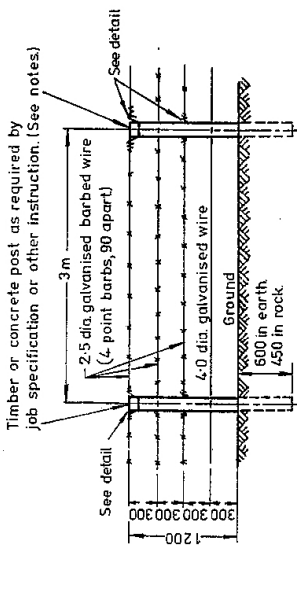

TYPICAL PANEL

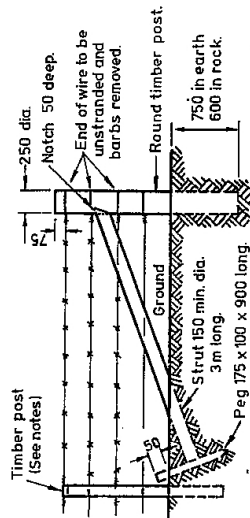

TIMBER STRAIN POST
END OR CORNER

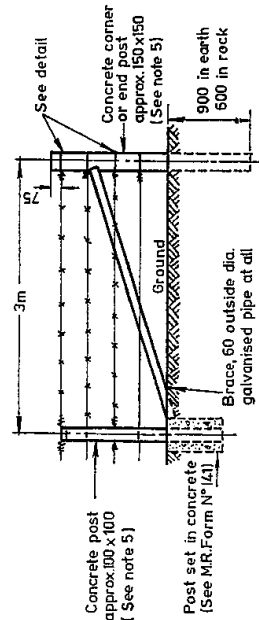

CONCRETE STRAIN POST
END OR CORNER

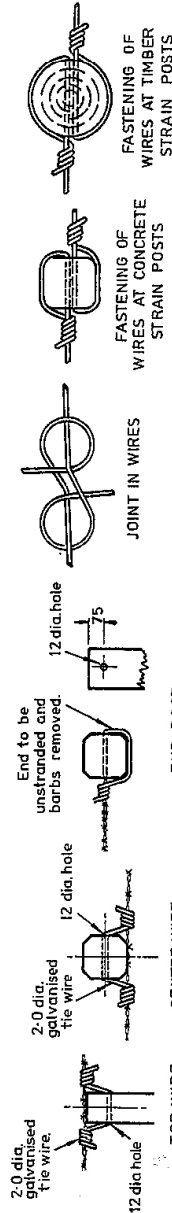

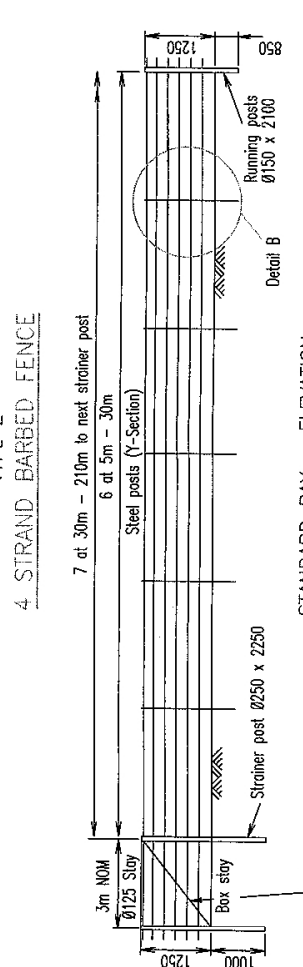
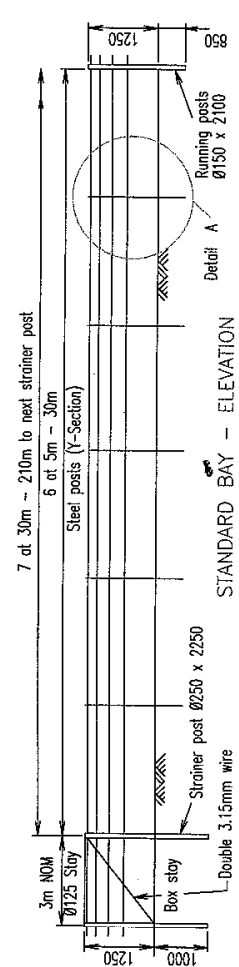
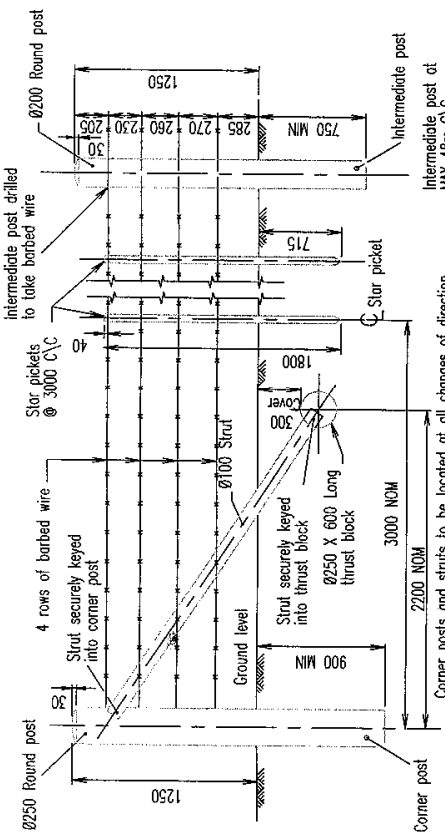
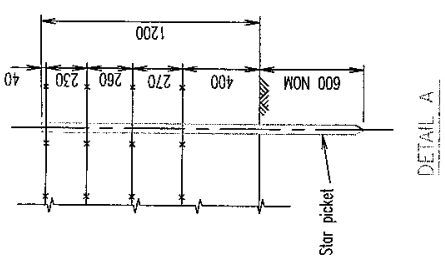
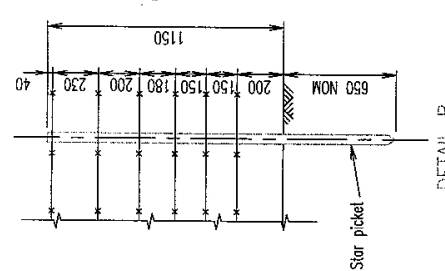

- NOTES**
1. Timber posts and struts shall be of approved hardwood.
 2. All barbed timber to be crosscut to AS1143.
 3. Steel posts are standard 1.8m (6 ft) BHP star pickets. Block for bronze star or galvanized to AS 1650, refer project documentation.
 4. At alignment changes of less than 90 degrees, the box stay bisects the angle of change.
 5. Galvanized fencing wire to AS 2423.
 6. All dimensions in millimetres, unless shown otherwise.

 <p>INSTITUTE OF PUBLIC WORKS ENGINEERING AUSTRALIA QUEENSLAND DIVISION INC.</p>		<p>FENCING</p> <p>4 & 6 STRAND BARBED WIRE FENCE</p>	<p>GENERAL Standard Drawing G-0040</p>						
<p>© INSTITUTE OF PUBLIC WORKS ENGINEERING AUSTRALIA QUEENSLAND DIVISION INC. - 1995 DISCLAIMER: The authors and sponsoring organisations shall have no liability or responsibility to the user or any other person or entity with respect to any liability, loss or damage caused or alleged to be caused, directly or indirectly, by the adoption and use of these Standard Drawings including, but not limited to, any interruption of service, loss of business or anticipatory profits, or consequential damages resulting from the use of these Standard Drawings. Persons must not rely on these Standard Drawings as the equivalent of, or a substitute for, project-specific design and assessment by an appropriately qualified professional.</p>		<table border="1"> <tr> <td>ORIGINAL ISSUE</td> <td>8/12/95</td> <td>DATE</td> </tr> <tr> <td>REVISIONS</td> <td></td> <td></td> </tr> </table>		ORIGINAL ISSUE	8/12/95	DATE	REVISIONS		
ORIGINAL ISSUE	8/12/95	DATE							
REVISIONS									

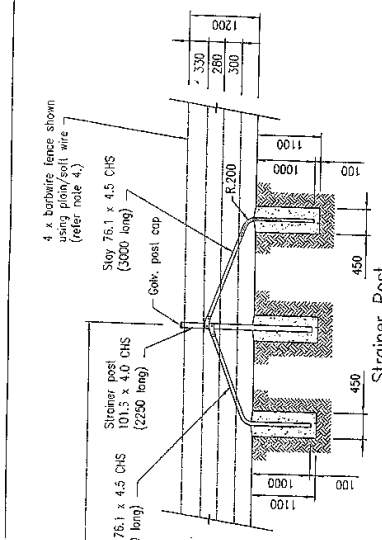

Strainer Post

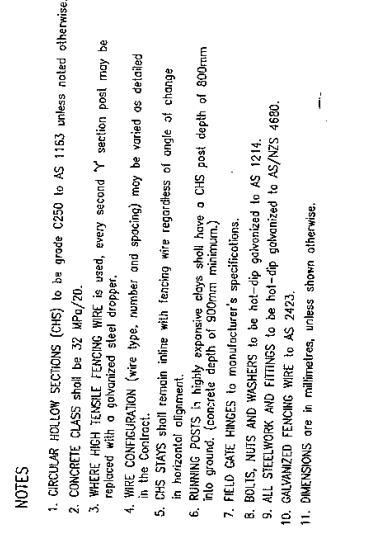

Running Post

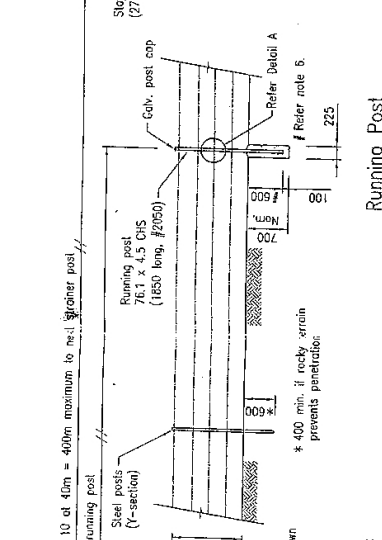

End Post

GENERAL ARRANGEMENT

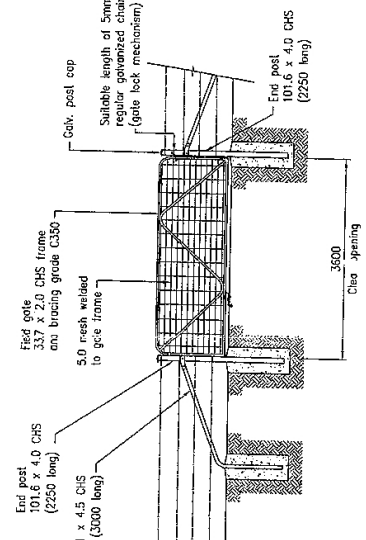

Steel Posts

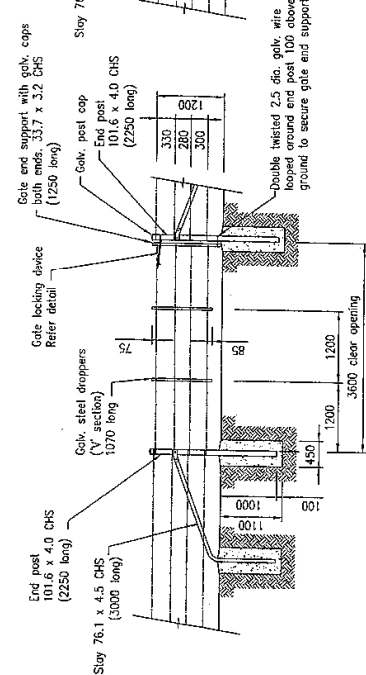

FIELD GATE DETAIL

BUSH GATE DETAIL

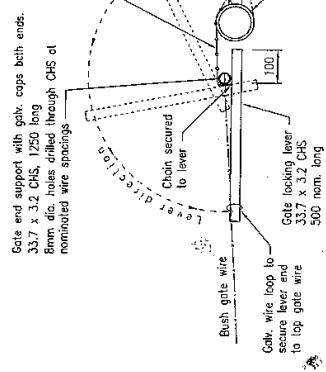

GATE LOCKING DEVICE - PLAN VIEW

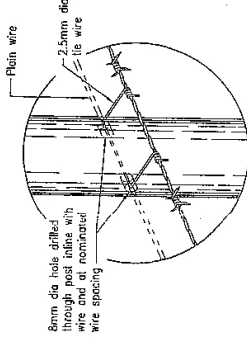

DETAIL A

NOTES

1. CIRCULAR HOLLOW SECTIONS (CHS) to be grade C250 to AS 1163 unless noted otherwise.
2. CONCRETE CLASS shall be 32 MPa/20.
3. WHERE HIGH TENSILE FENCING WIRE is used, every second 'Y' section post may be replaced with a galvanized steel dropper.
4. WIRE CONFIGURATION (wire type, number and spacing) may be varied as detailed in the Contract.
5. CHS STAYS shall remain inline with fencing wire regardless of angle of change in horizontal alignment.
6. RUNNING POSTS in highly expressive clays shall have a CHS post depth of 800mm into ground. (concrete depth of 900mm minimum.)
7. FIELD GATE HINGES to manufacturer's specifications.
8. BOLTS, NUTS AND WASHERS to be hot-dip galvanized to AS 1214.
9. ALL STEELWORK AND FITTINGS to be hot-dip galvanized to AS/NZS 4680.
10. GALVANIZED FENCING WIRE to AS 2423.
11. DIMENSIONS are in millimetres, unless shown otherwise.

ASSOCIATED DOCUMENTS:
 Department of Main Roads Manual of Standard Drawings Roads
 Department of Main Roads Manual of Standard Specifications Roads.

REFERENCED DOCUMENTS:
 Standard Specifications:
 Road Furniture
 Australian Standards:
 AS 1163 Structural Steel Hollow Sections
 AS 1214 Hot-Dip Galvanized Coatings on Threaded Fasteners (ISO method - zinc pre- and post- applied)
 AS 2423 Galvanized Wire Fencing Products
 AS/NZS 4680 Hot-Dip Galvanized (zinc) Coatings on Fabricated Ferrous Articles

 Queensland Government Department of Main Roads		Size A3	Drawing No
		Scales as shown	1601 Date 12/00
FENCING		RURAL FENCE AND GATES CHS POSTS AND STAYS	